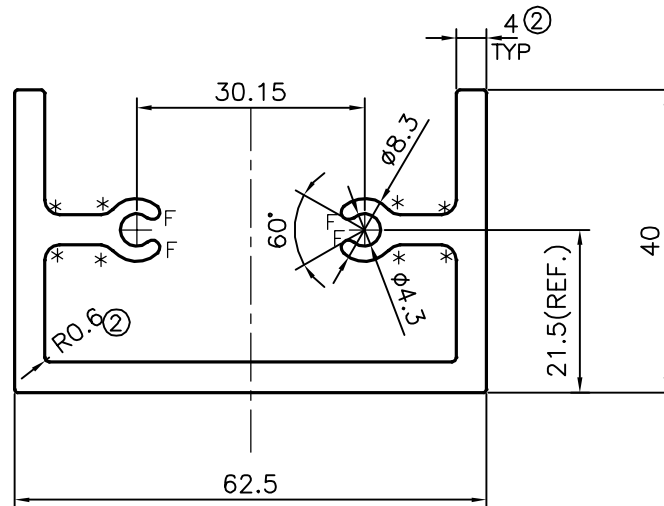

P-14663

S4475

35880

**ISSUE-2**

THICKNESS CHANGED FROM 3.0 TO 4.0 mm & INSIDE RADIUS CHANGED 0.4 mm TO 0.6 mm
WEIGHT ALSO CHANGED FROM 1.438 kg/m TO 1.813 kg/m

F = FULL RADIUS(4 PLACES)
* = 2.0 RADIUS (8 PLACES)

 SYMBOL OF QUALITY AN ISO 9002 COMPANY	JINDAL ALUMINIUM LTD. BANGALORE-560073 (INDIA)	NAME	DATE
		DRAWN	J.P.KAUSHIK
		CHECKED	
		APPROVED	B.NATARAJ
		SCALE	1:1
		AREA mm ²	671.605
		PERIMETER mm.	359.581
		WEIGHT kg/m	1.813
PARTY'S NAME	NIKITHA FACADE SYSTEMS, BANGALORE	DRAWING No.	SECTION No.
PARTY'S DRAWING No.	AS PER DRAWING NFS-DIE-7 & REQUIREMENT	P-14663	-
ALLOY & TEMPER	6063 T6	S4475	S4475
DESCRIPTION	CURTAIN WALL SECTION-TRANSOM CONNECTOR	35880	35880(ISSUE-2)