

P-13218

S3976

35888

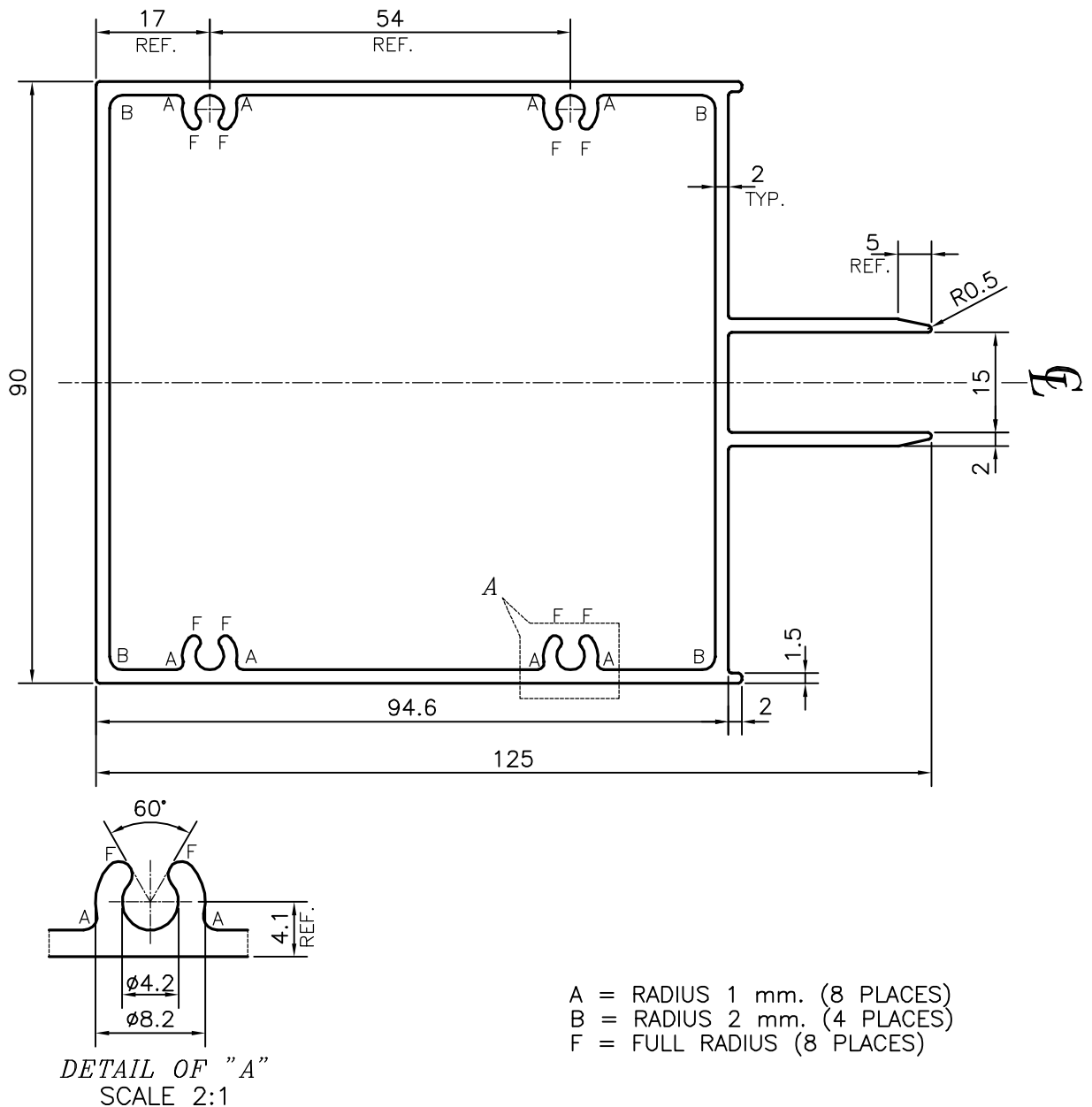

TOLERANCES ON OVERALL WIDTHS & WIDTHS ACROSS FLATS OF BARS, & REGULAR SECTIONS

UPTO 6.40mm - ±0.20	UPTO 32.0mm - ±0.38	UPTO 120.0mm - ±0.85	1. STRAIGHTNESS=0.7mm/M 2. TWIST=0.7mm/M 3. ANGULARITY= ±1' 4. FLATNESS =0.005xWIDTH
UPTO 10.0mm - ±0.23	UPTO 50.0mm - ±0.46	UPTO 160.0mm - ±1.02	
UPTO 12.0mm - ±0.25	UPTO 60.0mm - ±0.53	UPTO 200.0mm - ±1.14	
UPTO 16.0mm - ±0.28	UPTO 80.0mm - ±0.69	UPTO 250.0mm - ±1.40	
UPTO 25.0mm - ±0.30	UPTO 100.0mm - ±0.75	UPTO 300.0mm - ±1.65	

 SYMBOL OF QUALITY AN ISO 9001 COMPANY	<b>JINDAL ALUMINIUM LTD.</b> BANGALORE-560073 (INDIA)	NAME	DATE
		DRAWN	PARVESH 30-11-2013
		CHECKED	
		APPROVED	S.S.GARG 08-01-2014
1. ALL DIMENSIONS ARE IN mm. 2. ROUND OFF ALL SHARP CORNERS WITH 0.50 mm. 3. TOLERANCES WILL BE AS PER IS:6477-1983 , UNLESS OTHERWISE SPECIFIED		SCALE	1:1
		AREA mm <sup>2</sup>	937.497
		PERIMETER mm.	493.583
		WEIGHT kg/m	2.531
		DRAWING No.	SECTION No.
PARTY'S NAME	AAR AAR ENTERPRISES, NEW DELHI	P-13218	-
PARTY'S DRAWING No.	SECTION No-003	S3976	S3976
ALLOY & TEMPER	6063 T6	35888	35888
DESCRIPTION	CURTAIN WALL SECTION		