

P-11818-1

S3408

35914

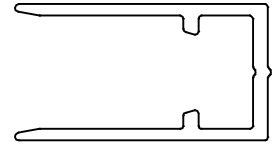

SCALE :- 1:1

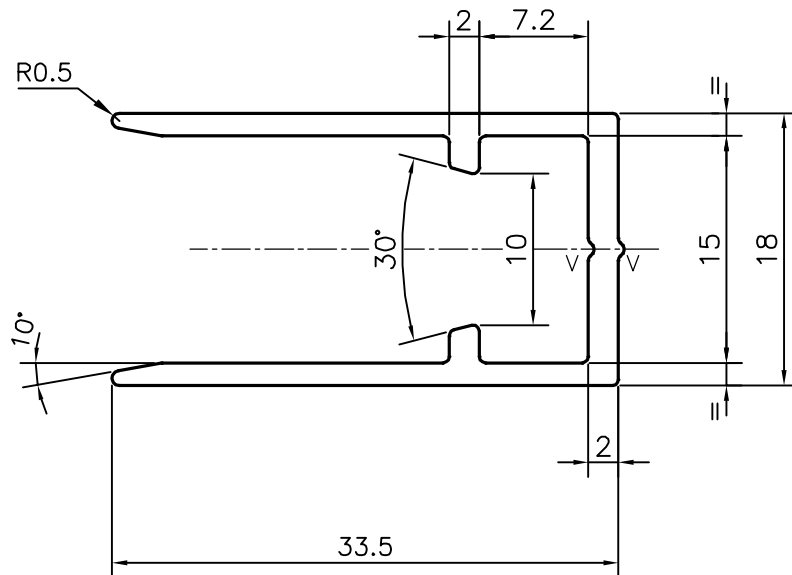

V = VEE GROOVE 0.4x90° (2 PLACE)



SYMBOL OF QUALITY  
AN ISO 9001 COMPANY

**JINDAL ALUMINIUM LTD.**  
BANGALORE-560073 (INDIA)

	NAME	DATE
DRAWN	PARVESH	18-06-2012
CHECKED		
APPROVED	S.S.GARG	19-07-2012

1. ALL DIMENSIONS ARE IN mm.
2. ROUND OFF ALL SHARP CORNERS WITH 0.40 mm.
3. TOLERANCES WILL BE AS PER IS:3965-1981, UNLESS OTHERWISE SPECIFIED

SCALE	2:1
AREA mm <sup>2</sup>	137.802
PERIMETER mm.	172.136
WEIGHT kg/m	0.372

PARTY'S NAME	TRUEWALL SPECIALITIES PVT. LTD., MUMBAI	DRAWING No.	P-11818-1	SECTION No.	-
PARTY'S DRAWING No.	AS PER DRAWING & REQUIREMENT	S3408	S3408		
ALLOY & TEMPER	6063 T6	35914	35914		
DESCRIPTION	CURTAIN WALL SECTION				