

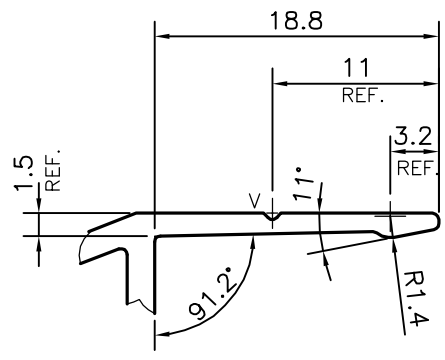

P-12130
S3514
35917

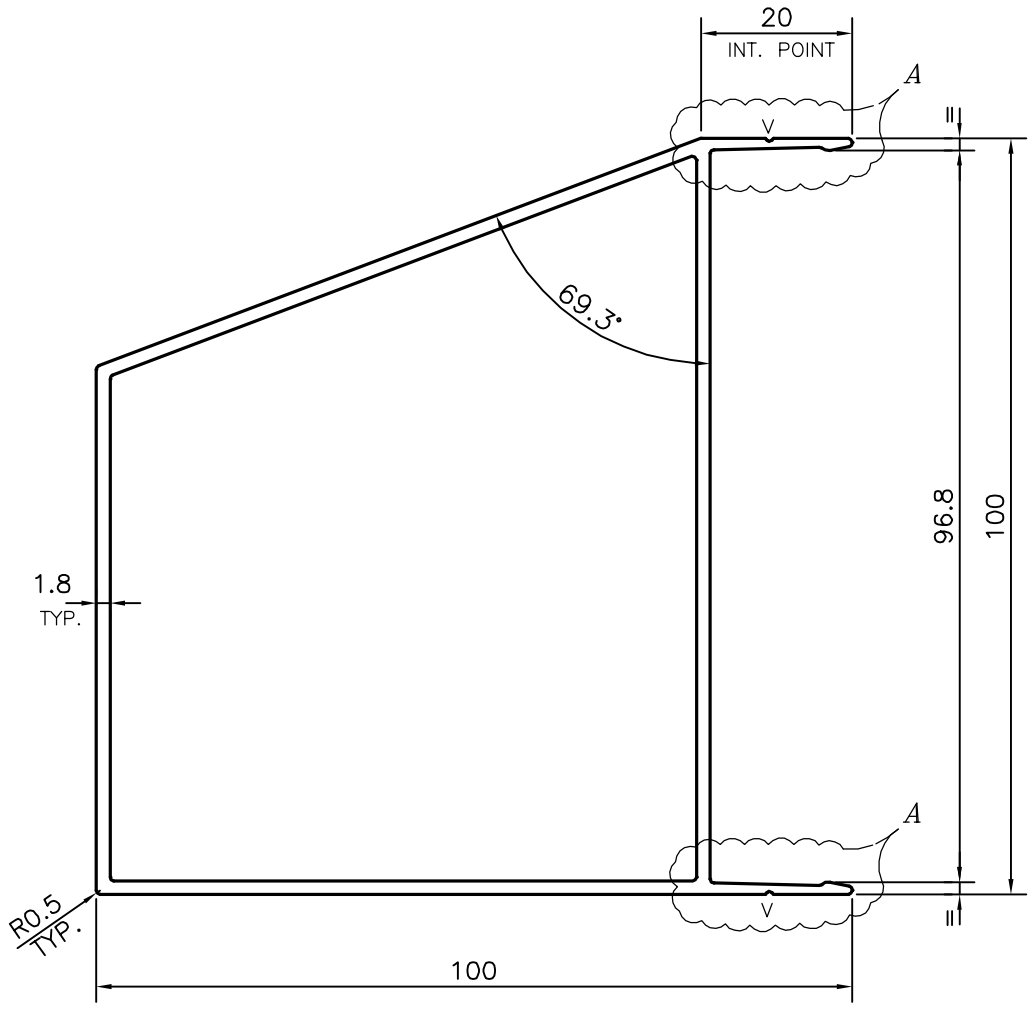

DETAIL OF "A"
SCALE 2:1

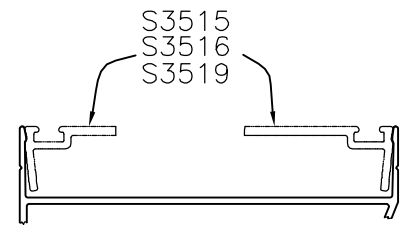

V = VEE GROOVE 0.4x90° (2 PLACES)

 SYMBOL OF QUALITY AN ISO 9001 COMPANY	JINDAL ALUMINIUM LTD. BANGALORE-560073 (INDIA)	DRAWN	NAME	DATE
		CHECKED	PARVESH	16-10-2012
1. ALL DIMENSIONS ARE IN mm. 2. ROUND OFF ALL SHARP CORNERS WITH 0.40 mm. 3. TOLERANCES WILL BE AS PER IS:6477-1983 UNLESS OTHERWISE SPECIFIED		APPROVED	S.S.GARG	25-10-2012
		SCALE		1:1
PARTY'S NAME TRUEWALL SPECIALITIES PVT. LTD., MUMBAI		AREA	mm ²	645.355
		PERIMETER	mm.	411.383
PARTY'S DRAWING No. CC-01		WEIGHT	kg/m	1.742
		DRAWING No.	SECTION No.	
ALLOY & TEMPER HE9 WP		P-12130	-	
		S3514	S3514	
DESCRIPTION CURTAIN WALL SECTION-COVER CAP		35917	35917	