

P-12131

S3515

35918

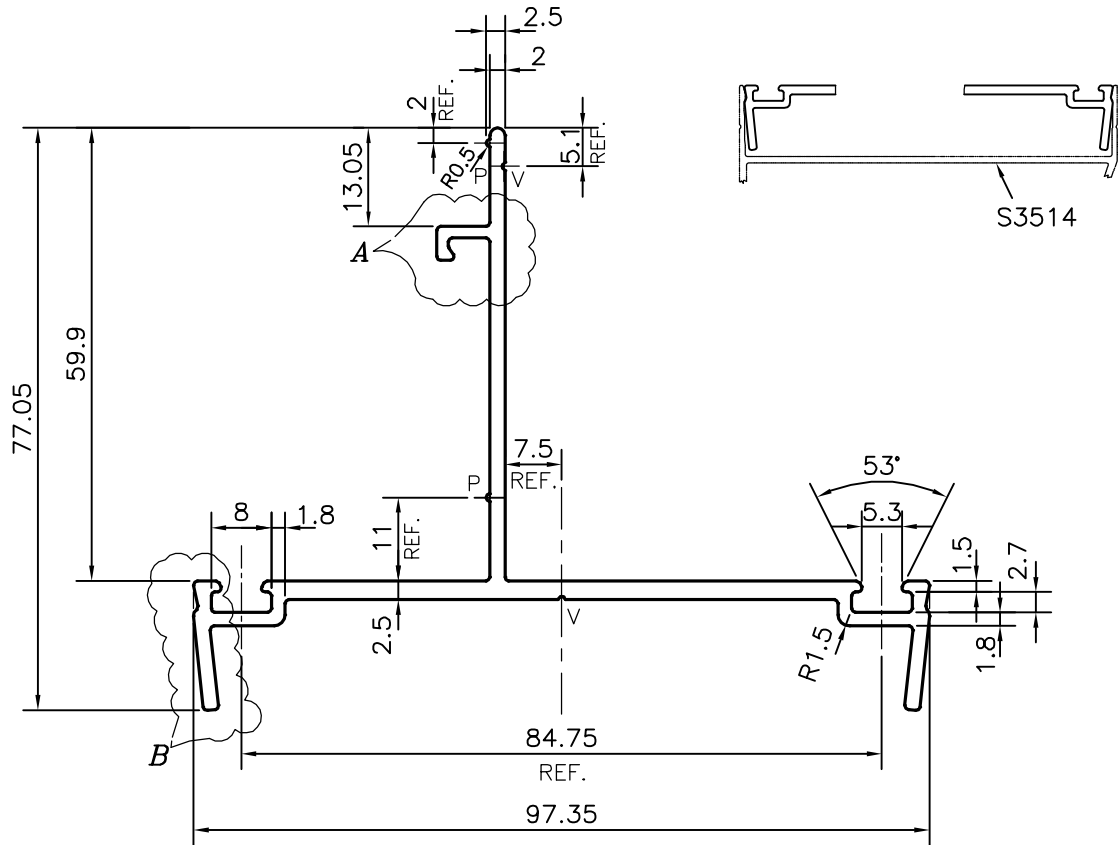

S3514

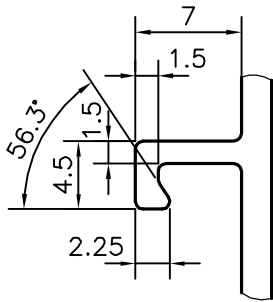

DETAIL OF "A"
SCALE :- 2:1

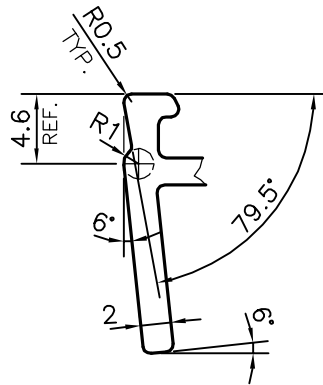

DETAIL OF "B"
SCALE :- 2:1

P = PIP 0.5 (2 PLACES)

V = VEE GROOVE 0.4x90° (2 PLACES)



SYMBOL OF QUALITY
AN ISO 9001 COMPANY

JINDAL ALUMINIUM LTD.
BANGALORE-560073 (INDIA)

	NAME	DATE
DRAWN	PARVESH	16-10-2012
CHECKED		
APPROVED	S.S.GARG	25-10-2012
SCALE		1:1
AREA mm ²		445.3
PERIMETER mm.		418.236
WEIGHT kg/m		1.202
DRAWING No.	SECTION No.	
P-12131	-	
S3515	S3515	
35918	35918	

1. ALL DIMENSIONS ARE IN mm.
2. ROUND OFF ALL SHARP CORNERS WITH 0.40 mm.
3. TOLERANCES WILL BE AS PER IS:3965-1981 UNLESS OTHERWISE SPECIFIED

PARTY'S NAME	TRUEWALL SPECIALITIES PVT. LTD., MUMBAI
PARTY'S DRAWING No.	PP-01
ALLOY & TEMPER	HE9 WP
DESCRIPTION	CURTAIN WALL SECTION-PRESSURE PLATE