

P-12132

S3516

35919

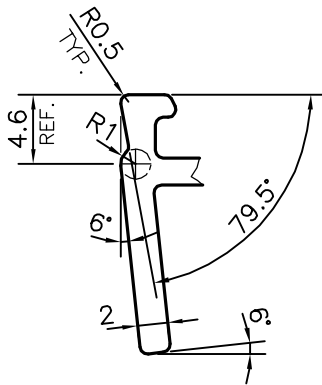
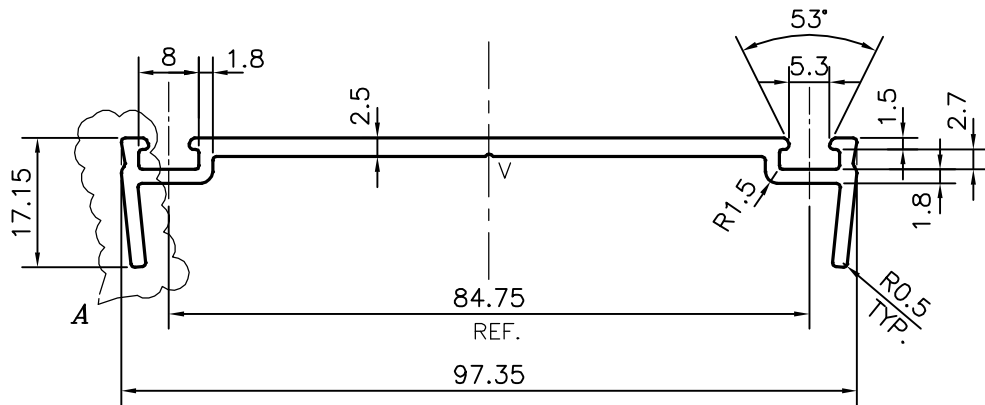
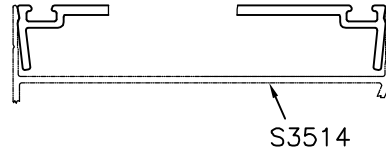

DETAIL OF "A"
SCALE :- 2:1

V = VEE GROOVE 0.4x90° (1 PLACES)

 SYMBOL OF QUALITY AN ISO 9001 COMPANY	JINDAL ALUMINIUM LTD. BANGALORE-560073 (INDIA)	NAME	DATE
		DRAWN	PARVESH 16-10-2012
1. ALL DIMENSIONS ARE IN mm. 2. ROUND OFF ALL SHARP CORNERS WITH 0.40 mm. 3. TOLERANCES WILL BE AS PER IS:3965-1981 UNLESS OTHERWISE SPECIFIED		CHECKED	
		APPROVED	S.S.GARG 25-10-2012
PARTY'S NAME TRUEWALL SPECIALITIES PVT. LTD., MUMBAI		SCALE	1:1
		AREA mm ²	309.382
PARTY'S DRAWING No. PP-02		PERIMETER mm.	278.605
		WEIGHT kg/m	0.835
ALLOY & TEMPER HE9 WP		DRAWING No.	SECTION No.
		P-12132	-
DESCRIPTION CURTAIN WALL SECTION-PRESSURE PLATE		S3516	S3516
		35919	35919