

P-12134

S3518

35921

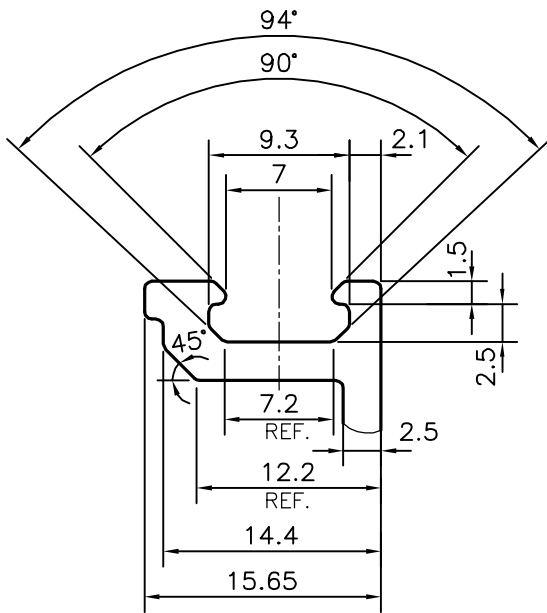
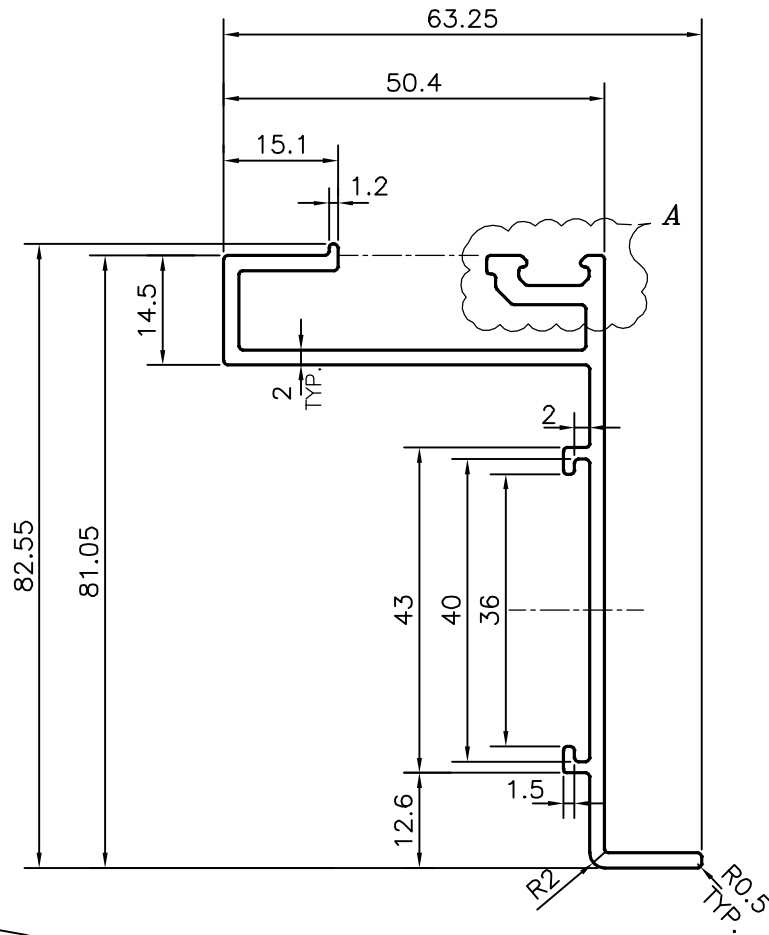

DETAIL OF "A"
SCALE:- 2:1



SYMBOL OF QUALITY
AN ISO 9001 COMPANY

JINDAL ALUMINIUM LTD.
BANGALORE-560073 (INDIA)

	NAME	DATE
DRAWN	PARVESH	16-10-2012
CHECKED		
APPROVED	S.S.GARG	25-10-2012
SCALE		1:1
AREA mm ²		404.673
PERIMETER mm.		391.925
WEIGHT kg/m		1.093
DRAWING No.	SECTION No.	
P-12134	-	
S3518	S3518	
35921	35921	

1. ALL DIMENSIONS ARE IN mm.
2. ROUND OFF ALL SHARP CORNERS WITH 0.40 mm.
3. TOLERANCES WILL BE AS PER IS:3965-1981 UNLESS OTHERWISE SPECIFIED

PARTY'S NAME	TRUEWALL SPECIALITIES PVT. LTD., MUMBAI
PARTY'S DRAWING No.	PP-05
ALLOY & TEMPER	HE9 WP
DESCRIPTION	CURTAIN WALL SECTION-TRAY HOLDER