

P-12135

S3519

35922

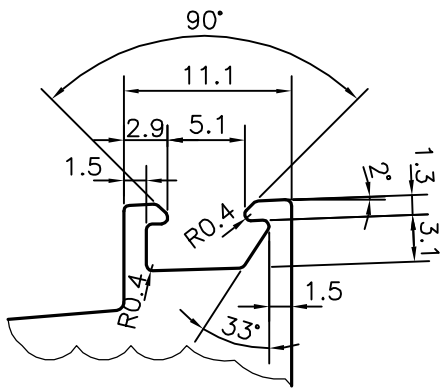
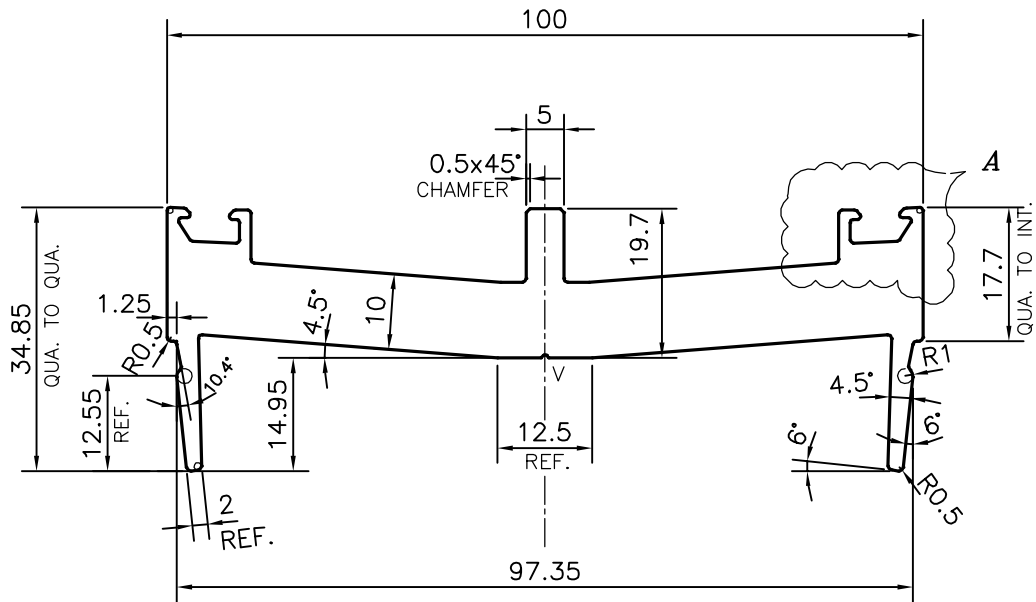

DETAIL OF "A"  
SCALE:- 2:1

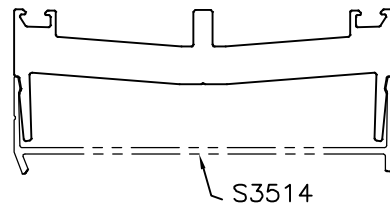

V = VEE GROOVE 0.4x90° (1 PLACE)



SYMBOL OF QUALITY  
AN ISO 9001 COMPANY

**JINDAL ALUMINIUM LTD.**  
BANGALORE-560073 (INDIA)

	NAME	DATE
DRAWN	PARVESH	16-10-2012
CHECKED		
APPROVED	S.S.GARG	25-10-2012
SCALE		1:1
AREA mm <sup>2</sup>		1233.601
PERIMETER mm.		357.986
WEIGHT kg/m		3.331
DRAWING No.	SECTION No.	
P-12135	-	
S3519	S3519	
35922	35922	

1. ALL DIMENSIONS ARE IN mm.
2. ROUND OFF ALL SHARP CORNERS WITH 0.40 mm.
3. TOLERANCES WILL BE AS PER IS:3965-1981 UNLESS OTHERWISE SPECIFIED

PARTY'S NAME	TRUEWALL SPECIALITIES PVT. LTD., MUMBAI
PARTY'S DRAWING No.	PP-03
ALLOY & TEMPER	HE9 WP
DESCRIPTION	CURTAIN WALL SECTION-PATCH1