

P-13610

S4131

35929

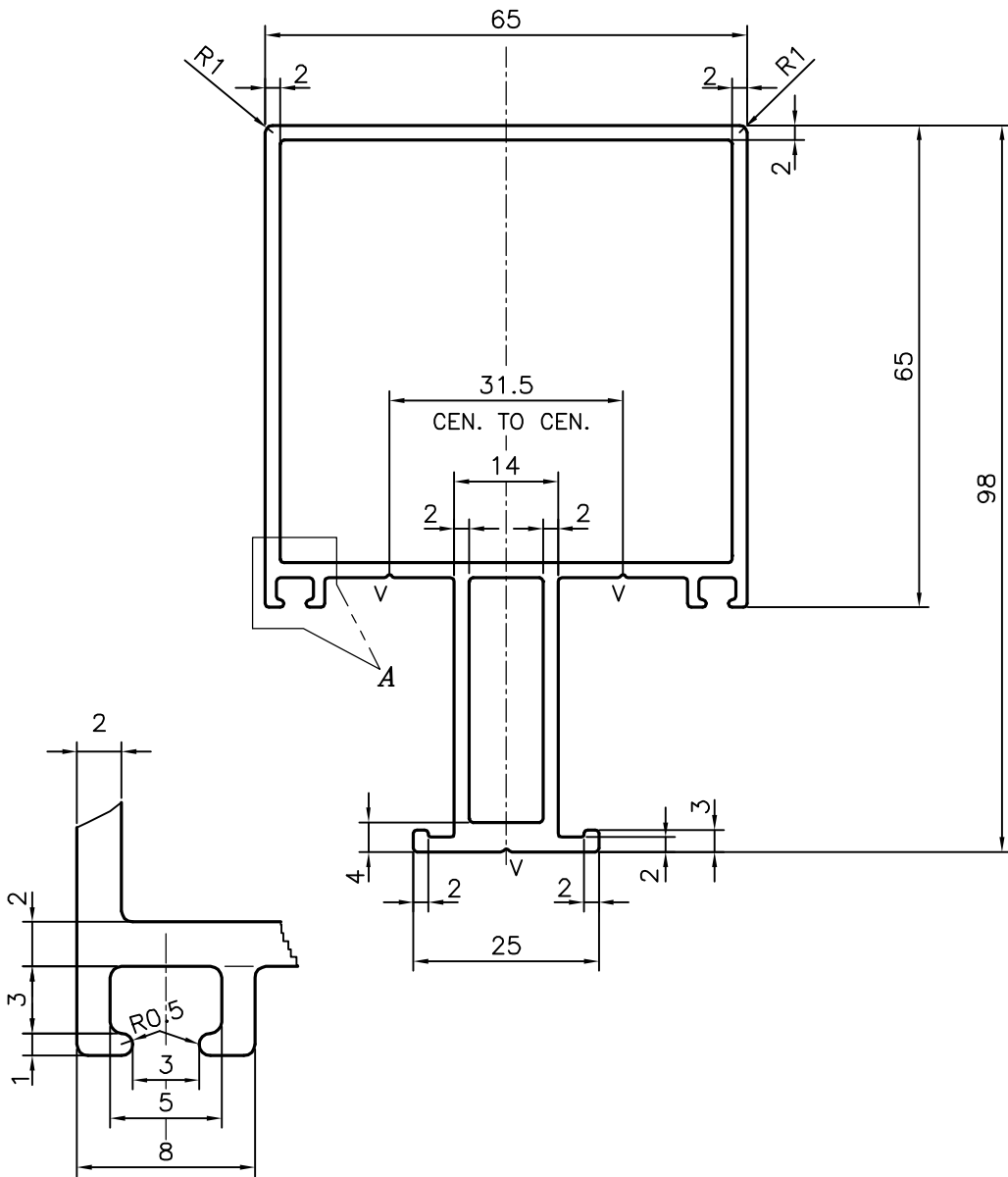

DETAIL OF "A"
SCALE 3:1

V = V GROOVE 0.4x90°(3 PLACES)

 SYMBOL OF QUALITY AN ISO 9002 COMPANY	JINDAL ALUMINIUM LTD. BANGALORE-560073 (INDIA)	NAME	DATE
		DRAWN	J.P.KAUSHIK 24-05-2014
		CHECKED	
		APPROVED	S.S.GARG 31-05-2014
		SCALE	1:1
		AREA mm ²	729.033
		PERIMETER mm.	384.822
		WEIGHT kg/m	1.968
PARTY'S NAME	HATIM GLAZING & CLADDING PVT. LTD., MUMBAI	DRAWING No.	SECTION No.
PARTY'S DRAWING No.	AS PER DRAWING (FULL TRANSOM)	P-13610	-
ALLOY & TEMPER	6063 T6	S4131	S4131
		35929	35929
DESCRIPTION	CURTAIN WALL SECTION (FULL TRANSOM)		