

P-13611

S4132

35930

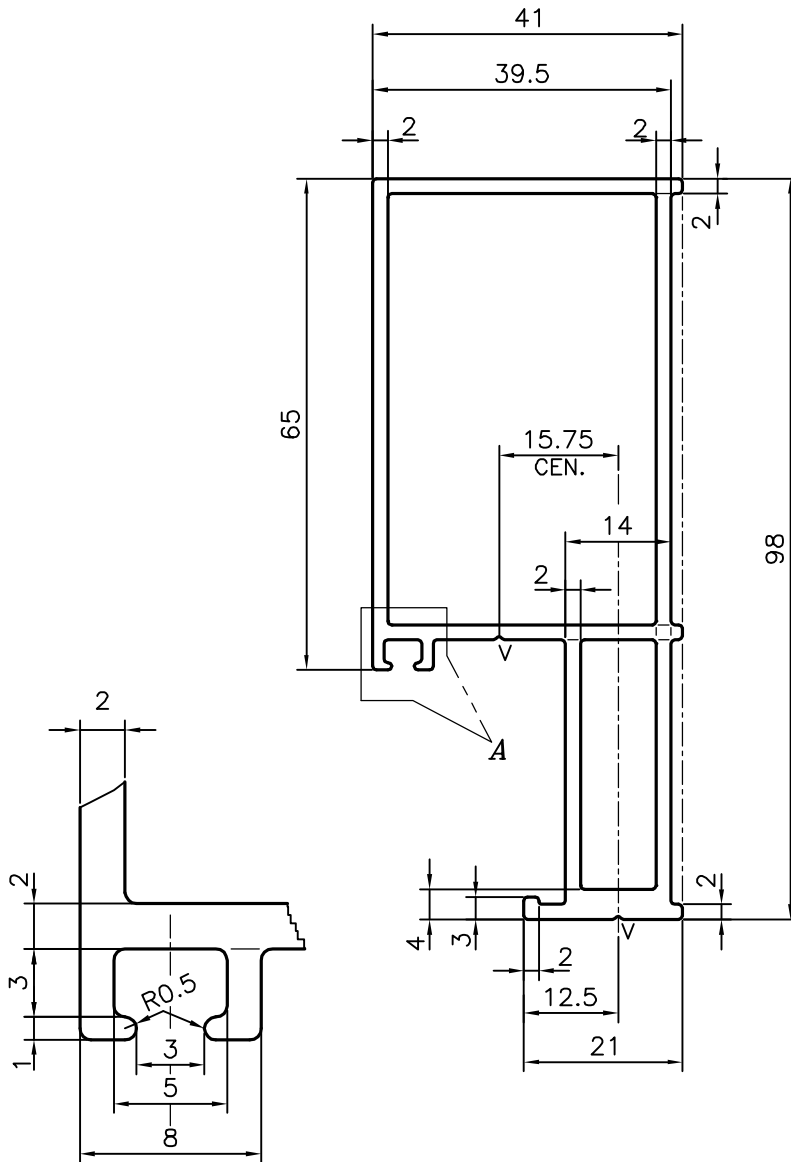

DETAIL OF "A"  
SCALE 3:1

V = V GROOVE 0.4x90°(2 PLACES)



SYMBOL OF QUALITY  
AN ISO 9002 COMPANY

**JINDAL ALUMINIUM LTD.**  
BANGALORE-560073 (INDIA)

	NAME	DATE
DRAWN	J.P.KAUSHIK	24-05-2014
CHECKED		
APPROVED	S.S.GARG	31-05-2014
SCALE		1:1
AREA mm <sup>2</sup>		609.648
PERIMETER mm.		311.602
WEIGHT kg/m		1.646
DRAWING No.	SECTION No.	
P-13611	-	
S4132	S4132	
35930	35930	

1. ALL DIMENSIONS ARE IN mm.
2. ROUND OFF ALL SHARP CORNERS WITH 0.50 mm.
3. TOLERANCES WILL BE AS PER IS:6477-1983 UNLESS OTHERWISE SPECIFIED

PARTY'S NAME	HATIM GLAZING & CLADDING PVT. LTD., MUMBAI
PARTY'S DRAWING No.	AS PER DRAWING (HALF TRANSOM)
ALLOY & TEMPER	6063 T6
DESCRIPTION	CURTAIN WALL SECTION (HALF TRANSOM)