

P-16024

S5023

35955

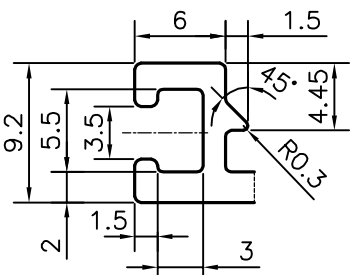
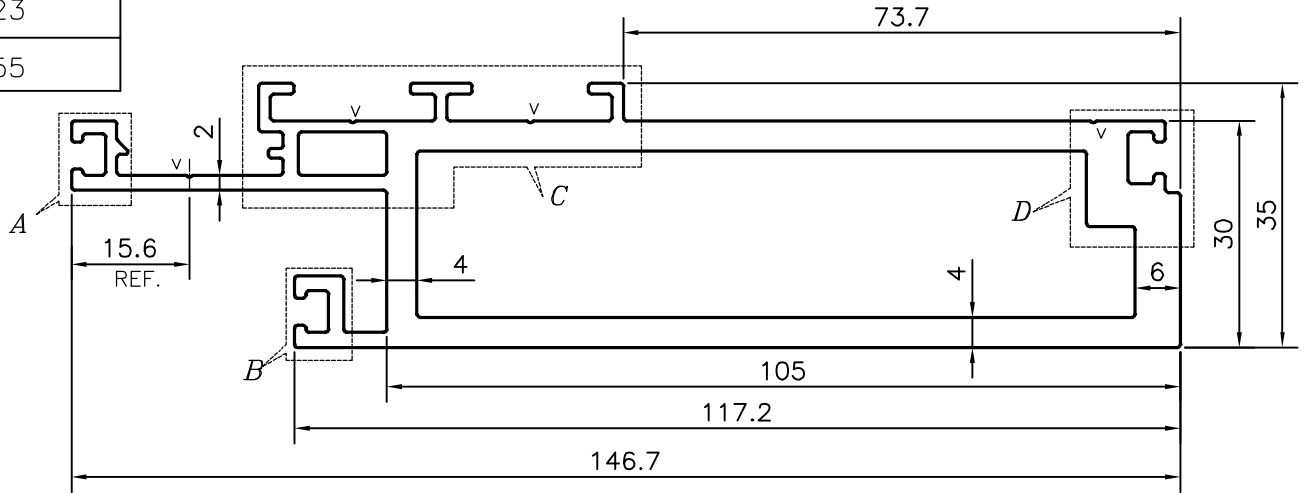

DETAIL OF "A"  
SCALE 2:1

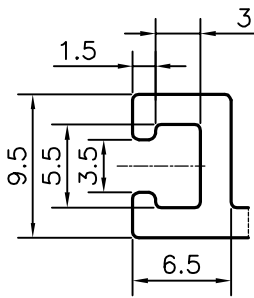

DETAIL OF "B"  
SCALE 2:1

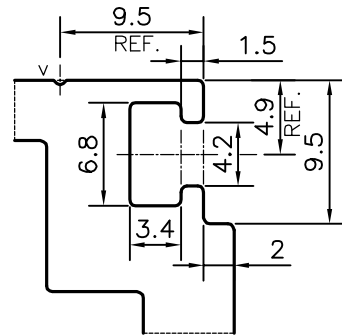

DETAIL OF "D"  
SCALE 2:1

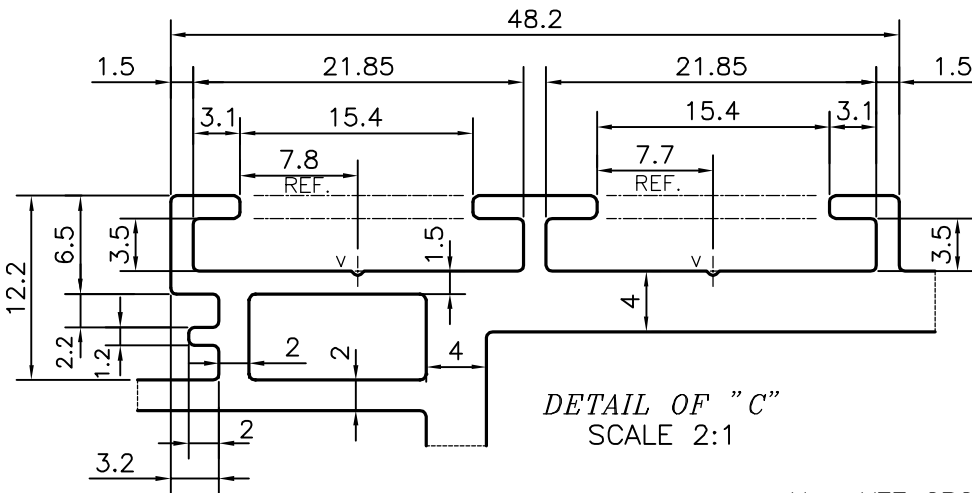

DETAIL OF "C"  
SCALE 2:1

V = VEE GROOVE 0.3x90° (4 PLACES)



SYMBOL OF QUALITY  
AN ISO 9001 COMPANY

**JINDAL ALUMINIUM LTD.**  
BANGALORE-560073 (INDIA)

	NAME	DATE
DRAWN	PARVESH	24-06-2016
CHECKED		
APPROVED	S.S. GARG	11-07-2016
SCALE		1:1
AREA mm <sup>2</sup>		1314.103
PERIMETER mm.		506.094
WEIGHT kg/m		3.548
DRAWING No.	SECTION No.	
P-16024	-	
S5023	S5023	
35955	35955	

1. ALL DIMENSIONS ARE IN mm.
2. ROUND OFF ALL SHARP CORNERS WITH 0.40 mm.
3. TOLERANCES WILL BE AS PER IS:6477-1983, UNLESS OTHERWISE SPECIFIED

PARTY'S NAME	AHLUWALIA CONTRACTS (INDIA) LTD., MUMBAI
PARTY'S DRAWING No.	AS PER AUTOCAD DRAWING
ALLOY & TEMPER	6063 T6
DESCRIPTION	CURTAIN WALL SECTION