

P-14840

S4529

35956

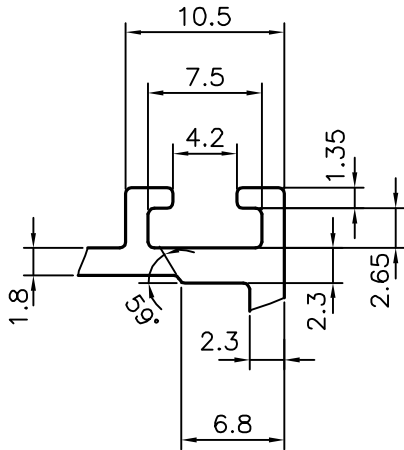

DETAIL OF "B"  
SCALE 2:1

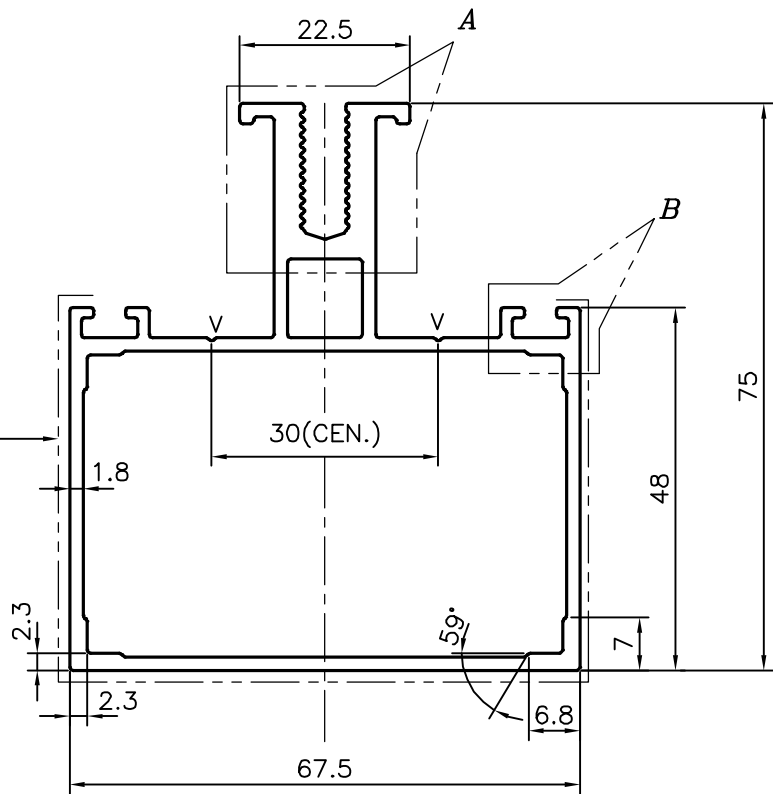
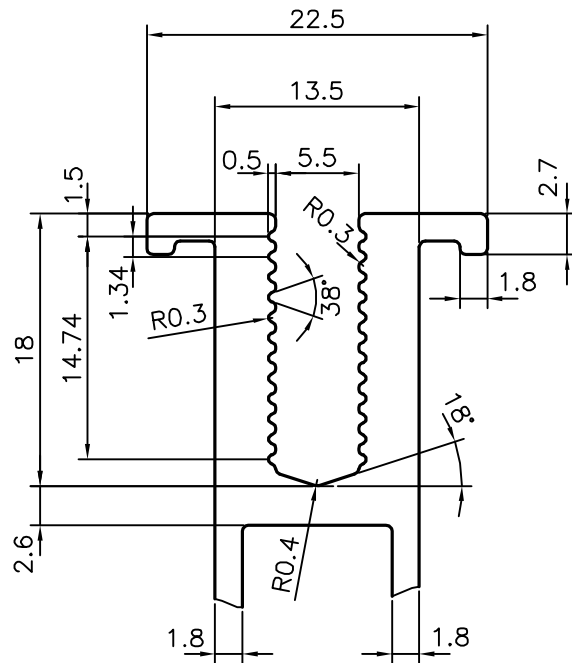

EXPOSED SURFACE

V = V GROOVE 0.4x90° ( 2 PLACES)



SYMBOL OF QUALITY  
AN ISO 9002 COMPANY

**JINDAL ALUMINIUM LTD.**  
BANGALORE-560073 (INDIA)

	NAME	DATE
DRAWN	J.P.KAUSHIK	04-07-2015
CHECKED		
APPROVED	S.S.GARG	11-07-2015
SCALE		1:1
AREA mm <sup>2</sup>		671.421
PERIMETER mm.		391.842
WEIGHT kg/m		1.813
DRAWING No.	SECTION No.	
P-14840	-	
S4529	S4529	
35956	35956	

1. ALL DIMENSIONS ARE IN mm.
2. ROUND OFF ALL SHARP CORNERS WITH 0.40 mm.
3. TOLERANCES WILL BE AS PER IS:6477-1983 UNLESS OTHERWISE SPECIFIED

PARTY'S NAME	D K GLAZING WORKS, GURGAON
PARTY'S DRAWING No.	AS PER DRAWING
ALLOY & TEMPER	HE9 WP
DESCRIPTION	CURTAIN WALL SECTION