

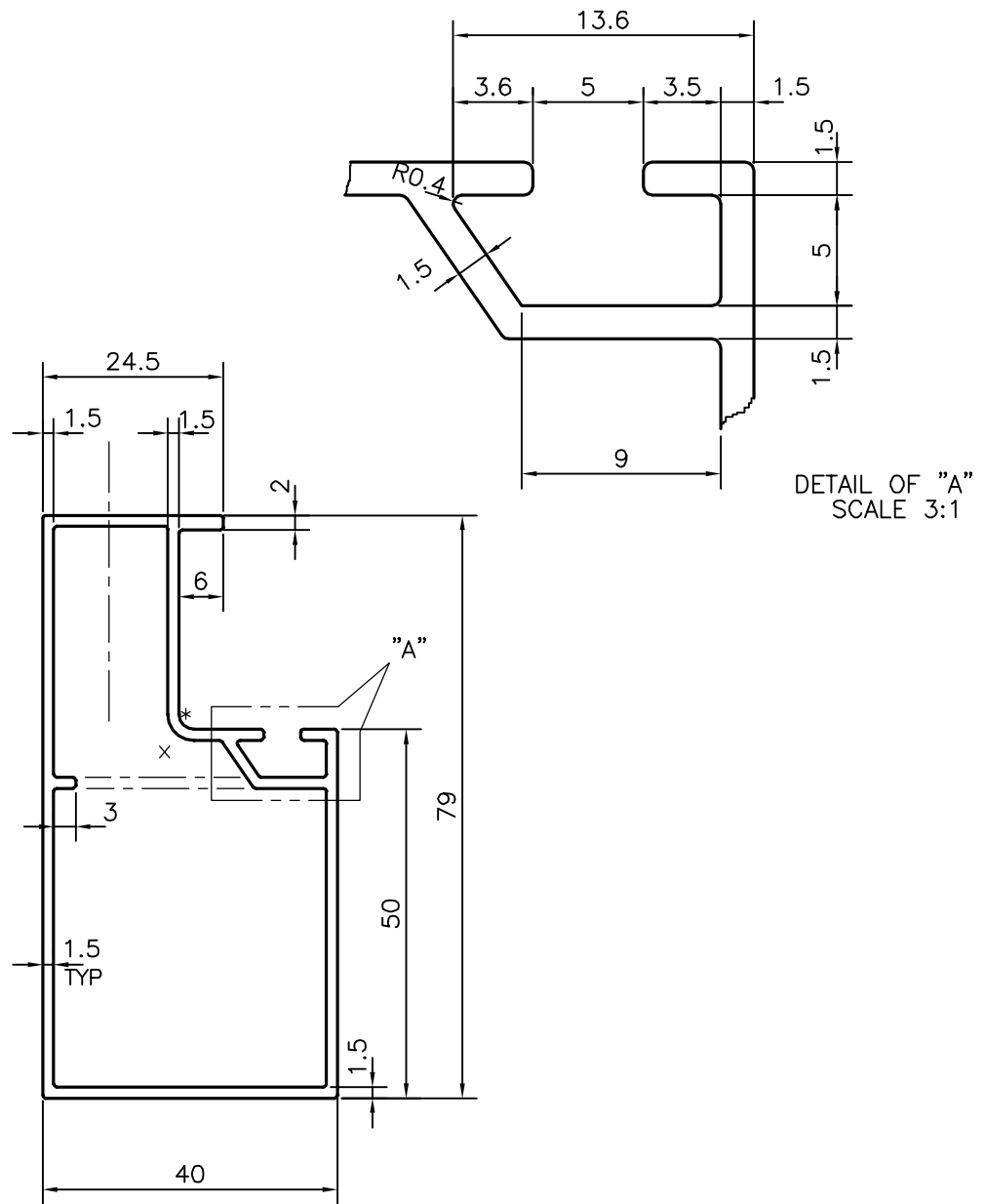

P-11454
X1567
35958



x = 3.5 RADIUS ( 1 PLACES )  
 \* = 2.0 RADIUS ( 1 PLACES )

 SYMBOL OF QUALITY AN ISO 9001 COMPANY	<b>JINDAL ALUMINIUM LTD.</b> BANGALORE-560073 (INDIA)	DRAWN	NAME	DATE
		CHECKED	J.P.KAUSHIK	10-01-2012
1. ALL DIMENSIONS ARE IN mm. 2. ROUND OFF ALL SHARP CORNERS WITH 0.40 mm. 3. TOLERANCES WILL BE AS PER,IS:6477-1983 UNLESS OTHERWISE SPECIFIED		APPROVED	B.NATARAJ	30-01-2012
		SCALE		1:1
PARTY'S NAME AMBICA ALUMINIUM CO., BANGALORE		AREA	mm <sup>2</sup>	379.88
		PERIMETER	mm.	271.766
PARTY'S DRAWING No. SPF-0001		WEIGHT	kg/m	1.026
		DRAWING No.	SECTION No.	
ALLOY & TEMPER HE9 WP		P-11454	-	
		X1567	X1567	
DESCRIPTION CURTAIN WALL SECTION		35958	35958	