

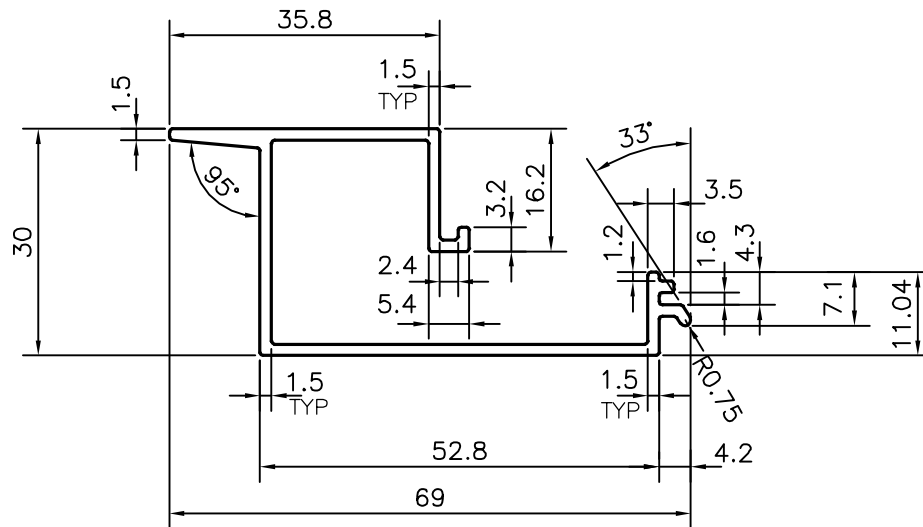

P-11457
X1570
35961



F = FULL RADIUS

 SYMBOL OF QUALITY AN ISO 9001 COMPANY	JINDAL ALUMINIUM LTD. BANGALORE-560073 (INDIA)	DRAWN	J.P.KAUSHIK	10-01-2012
		CHECKED		
1. ALL DIMENSIONS ARE IN mm. 2. ROUND OFF ALL SHARP CORNERS WITH 0.40 mm. 3. TOLERANCES WILL BE AS PER,IS:3965-1981 UNLESS OTHERWISE SPECIFIED		APPROVED	B.NATARAJ	30-01-2012
		SCALE		1:1
PARTY'S NAME AMBICA ALUMINIUM CO., BANGALORE		AREA	mm ²	234.106
		PERIMETER	mm.	301.915
PARTY'S DRAWING No. SPF-0004		WEIGHT	kg/m	0.632
		DRAWING No.		SECTION No.
ALLOY & TEMPER HE9 WP		P-11457		-
		X1570		X1570
DESCRIPTION CURTAIN WALL SECTION		35961		35961