

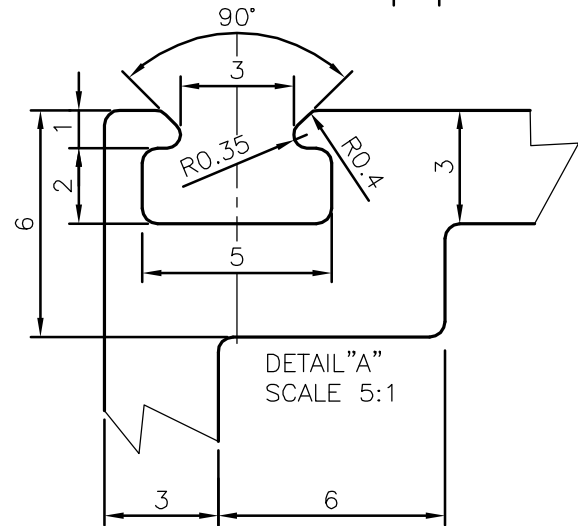

P-15624
S4943
35962

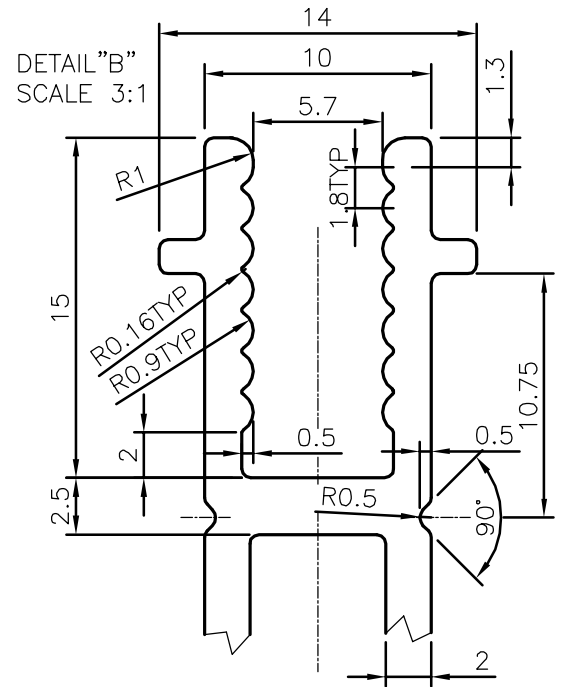
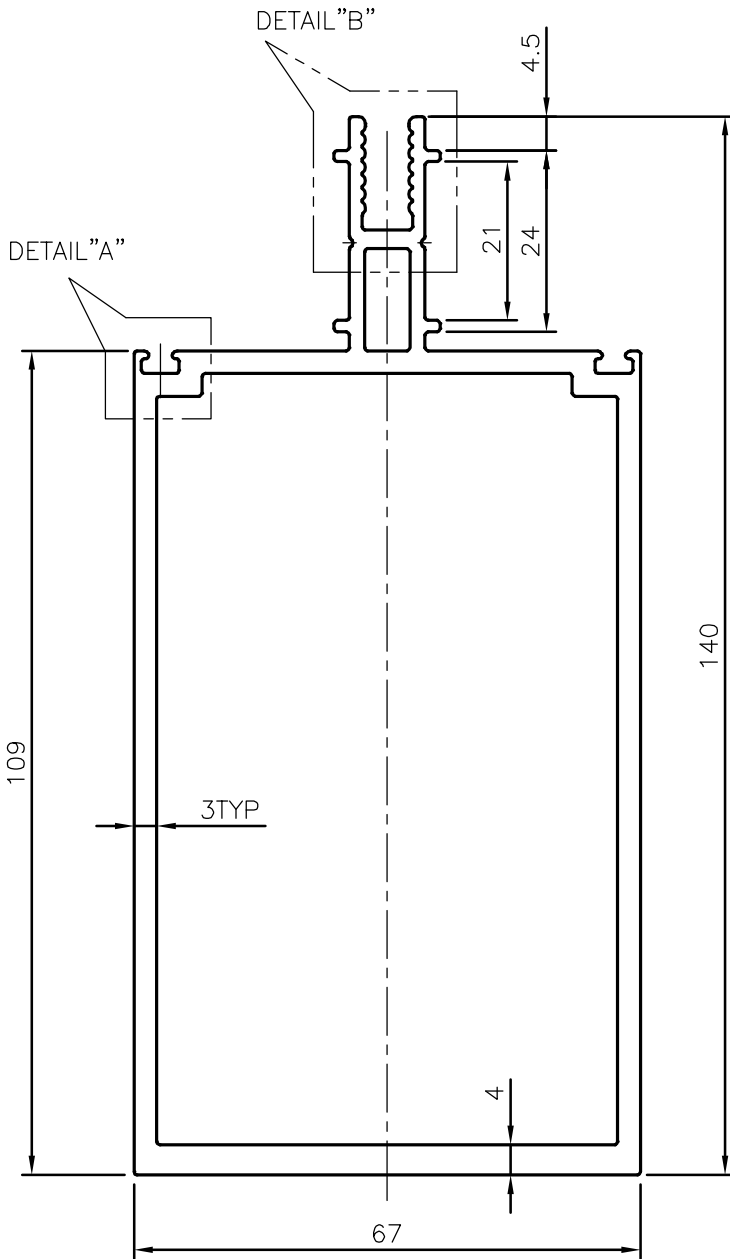

 SYMBOL OF QUALITY AN ISO 9002 COMPANY	JINDAL ALUMINIUM LTD. BANGALORE-560073 (INDIA)	NAME	DATE
		DRAWN	J.P.KAUSHIK
		CHECKED	
		APPROVED	S.S. GARG
		SCALE	1:1
		AREA mm ²	1238.85
		PERIMETER mm.	477.577
		WEIGHT kg/m	3.345
		DRAWING No.	SECTION No.
		P-15624	-
		S4943	S4943
		35962	35962
PARTY'S NAME	RADIANCE CONSTRUCTION, HOOGHLY		
PARTY'S DRAWING No.	AS PER DRAWING-MODIFIED OF 22844		
ALLOY & TEMPER	6063 T6		
DESCRIPTION	CURTAIN WALL SECTION-MULLION		

1. ALL DIMENSIONS ARE IN mm.
2. ROUND OFF ALL SHARP CORNERS WITH 0.40 mm.
3. TOLERANCES WILL BE AS PER IS:6477-1983 UNLESS OTHERWISE SPECIFIED