

P-16661

S5217

35963

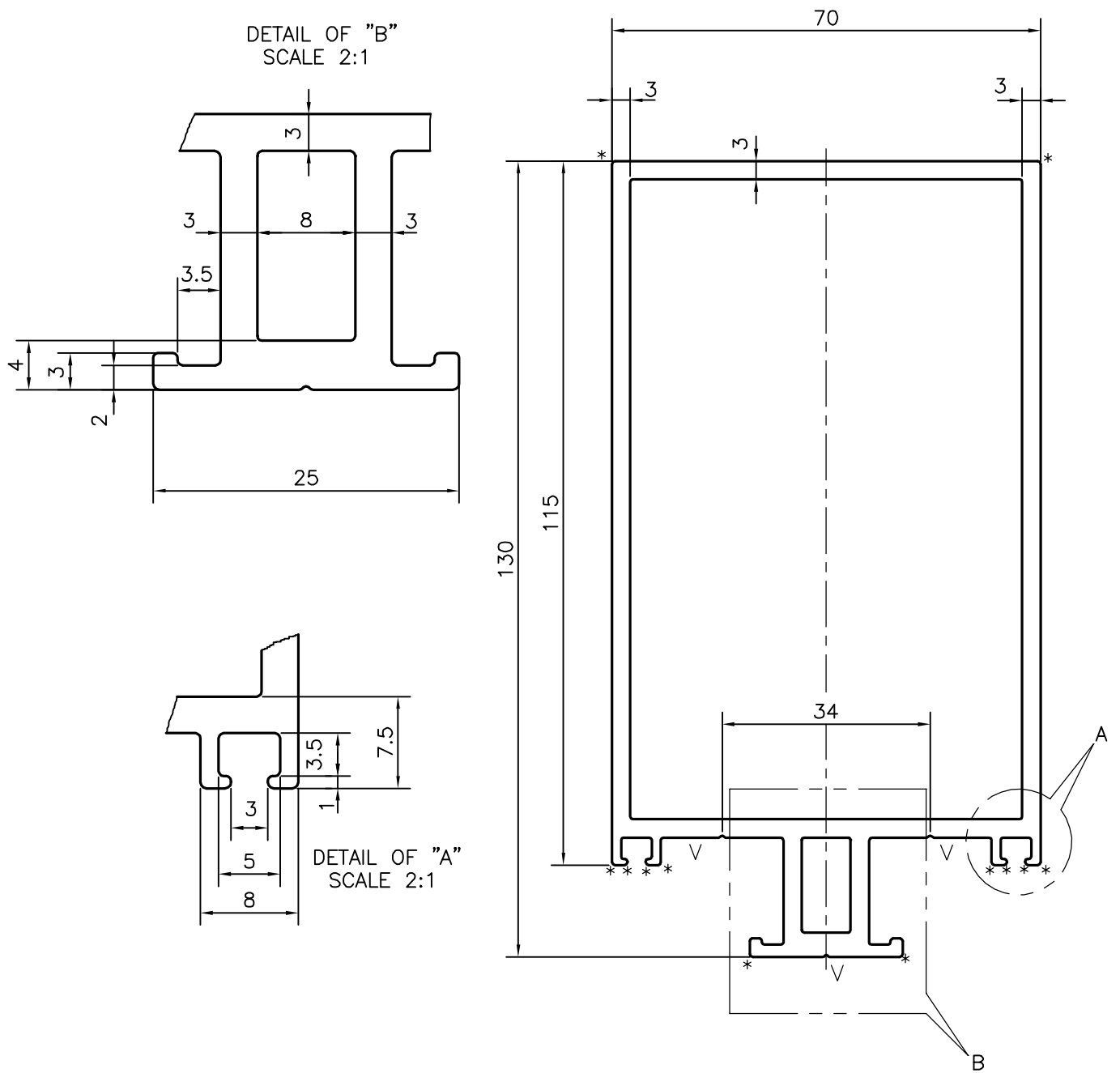

V = V GROOVE 0.3x90° (3 PLACES)
 * = R0.50 mm (12 PLACES)



SYMBOL OF QUALITY
 AN ISO 9001 COMPANY

JINDAL ALUMINIUM LTD.
 BANGALORE-560073 (INDIA)

	NAME	DATE
DRAWN	J.P.KAUSHIK	24-12-2016
CHECKED		
APPROVED	B.NATARAJ	27-12-2016
SCALE		1:1
AREA mm ²		1252.441
PERIMETER mm.		463.783
WEIGHT kg/m		3.382
DRAWING No.	SECTION No.	
P-16661		
S5217	S5217	
35963	35963	

1. ALL DIMENSIONS ARE IN mm.
2. ROUND OFF ALL SHARP CORNERS WITH 0.40 mm.
3. TOLERANCES WILL BE AS PER IS:6477-1983 UNLESS OTHERWISE SPECIFIED

PARTY'S NAME	SHREE ENTERPRISES, PUNE
PARTY'S DRAWING No.	AS PER AutoCAD DRAWING
ALLOY & TEMPER	6063 T6
DESCRIPTION	CURTAIN WALL SECTION