

P-16664
S5220
35966

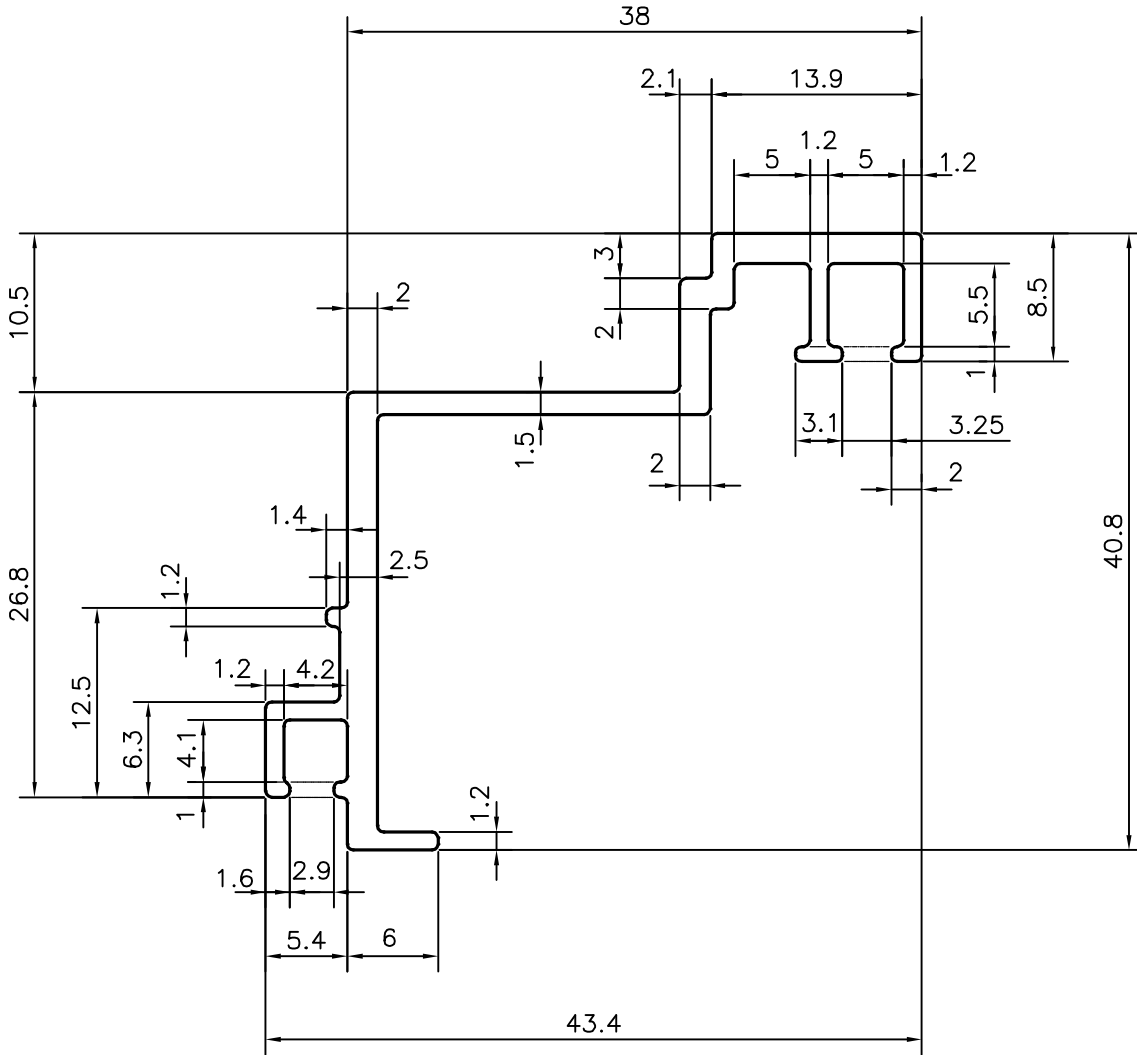
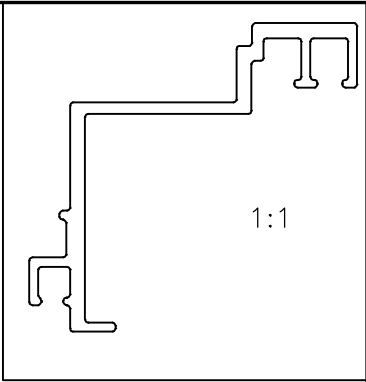

**JINDAL ALUMINIUM LTD.**  
 BANGALORE-560073 (INDIA)

	NAME	DATE
DRAWN	J.P.KAUSHIK	24-12-2016
CHECKED		
APPROVED	B.NATARAJ	27-12-2016

1. ALL DIMENSIONS ARE IN mm.
2. ROUND OFF ALL SHARP CORNERS WITH 0.40 mm.
3. TOLERANCES WILL BE AS PER,IS:3965-1981 UNLESS OTHERWISE SPECIFIED

SCALE	2:1
AREA mm <sup>2</sup>	182.121
PERIMETER mm.	214.934
WEIGHT kg/m	0.492

PARTY'S NAME	SHREE ENTERPRISES, PUNE
PARTY'S DRAWING No.	AS PER AutoCAD DRAWING
ALLOY & TEMPER	6063 T6
DESCRIPTION	ADAPTER SECTION

DRAWING No.	SECTION No.
P-16664	-
S5220	S5220
35966	35966