

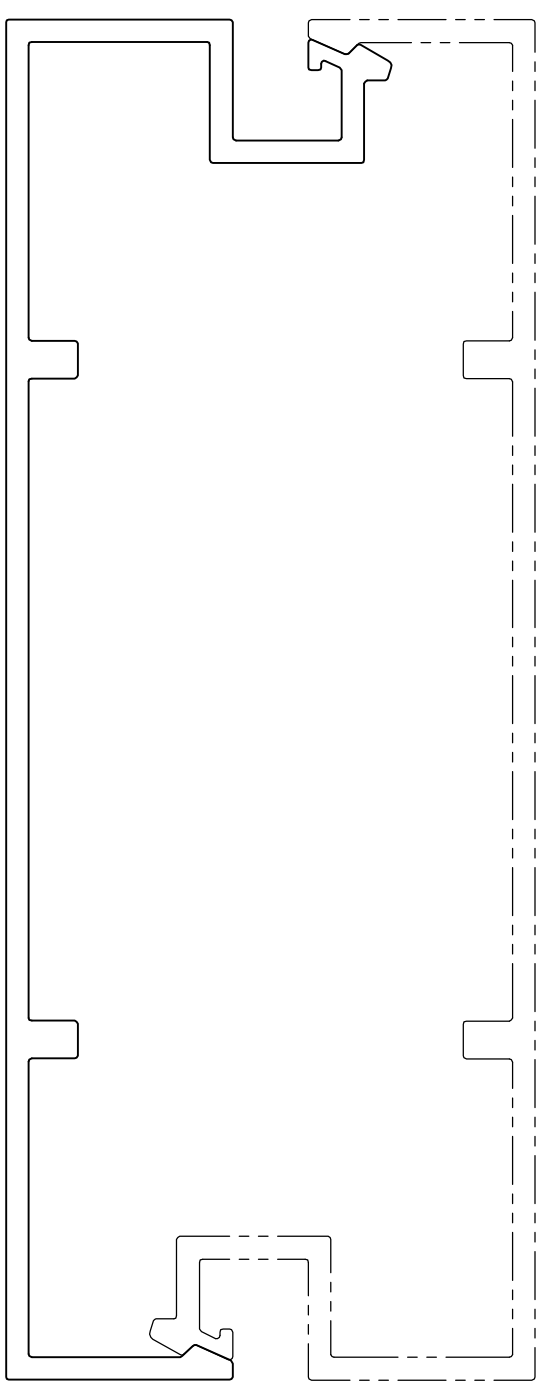

P-14800-2
S4506
35982

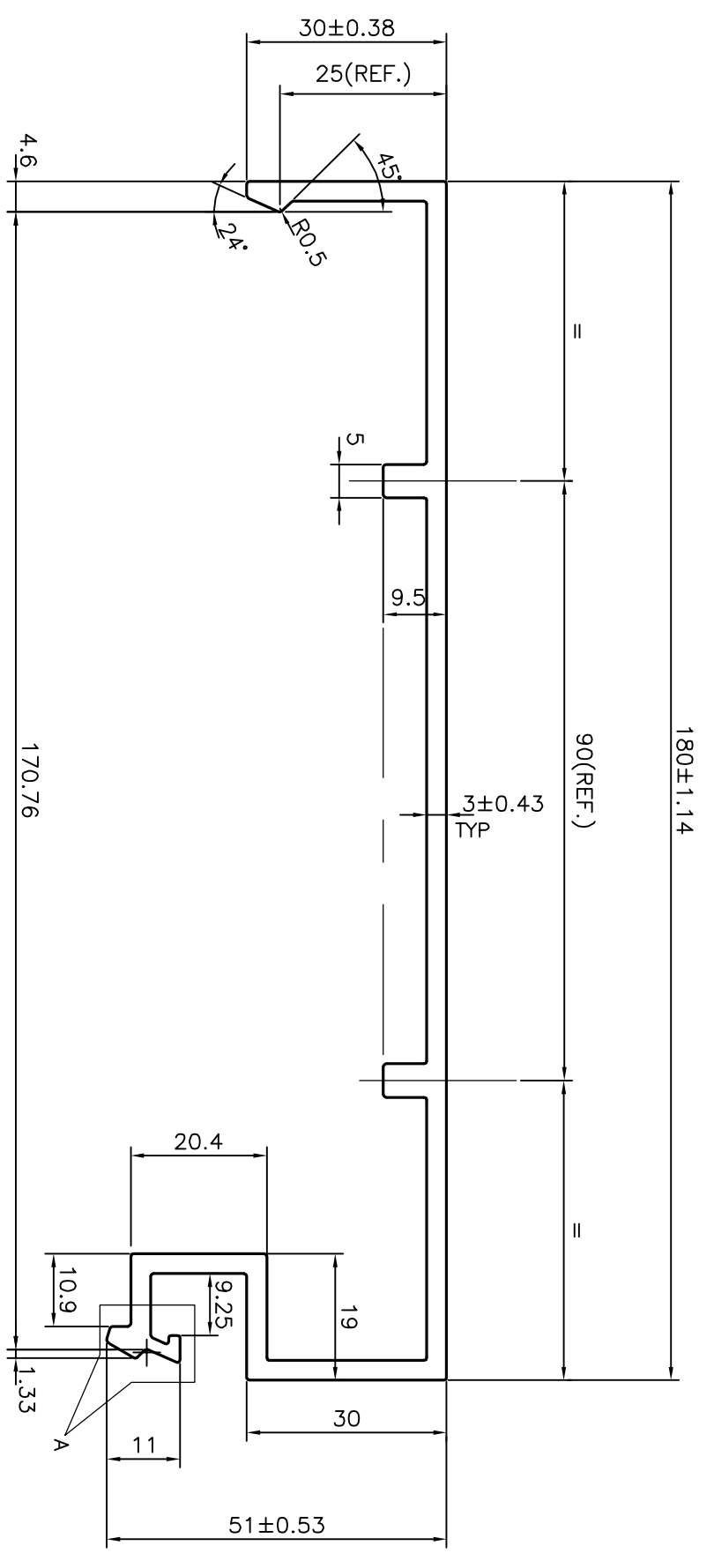
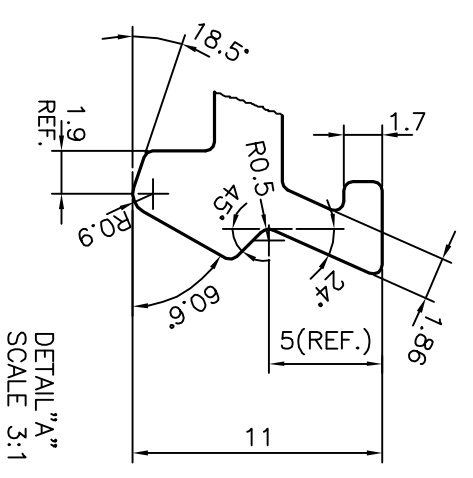

 SYMBOL OF QUALITY AN ISO 9002 COMPANY	JINDAL ALUMINIUM LTD. BANGALORE-560073 (INDIA)		DRAWN J.P. KAUSHIK 27-06-2015	NAME J.P. KAUSHIK DATE 27-06-2015
	1. ALL DIMENSIONS ARE IN mm. 2. ROUND OFF ALL SHARP CORNERS WITH 0.40 mm. 3. TOLERANCES WILL BE AS PER IS:3965-1981 UNLESS OTHERWISE SPECIFIED		CHECKED APPROVED S.S.GARG 02-07-2015	SCALE 1:1
PARTY'S NAME SREE MUGAMBIGAI GLAZING PVT. LTD., BANGALORE	AREA mm ² 931.462		PERIMETER mm. 605.333	
PARTY'S DRAWING No. AS PER AutocAD DRAWING	WEIGHT kg/m 2.515		DRAWING No. SECTION No.	
ALLOY & TEMPER HE9 WP	P-14800-2 S4506		- S4506	
DESCRIPTION TRANSOM SECTION	35982		35982	