

P-15241-1

S4726

35987

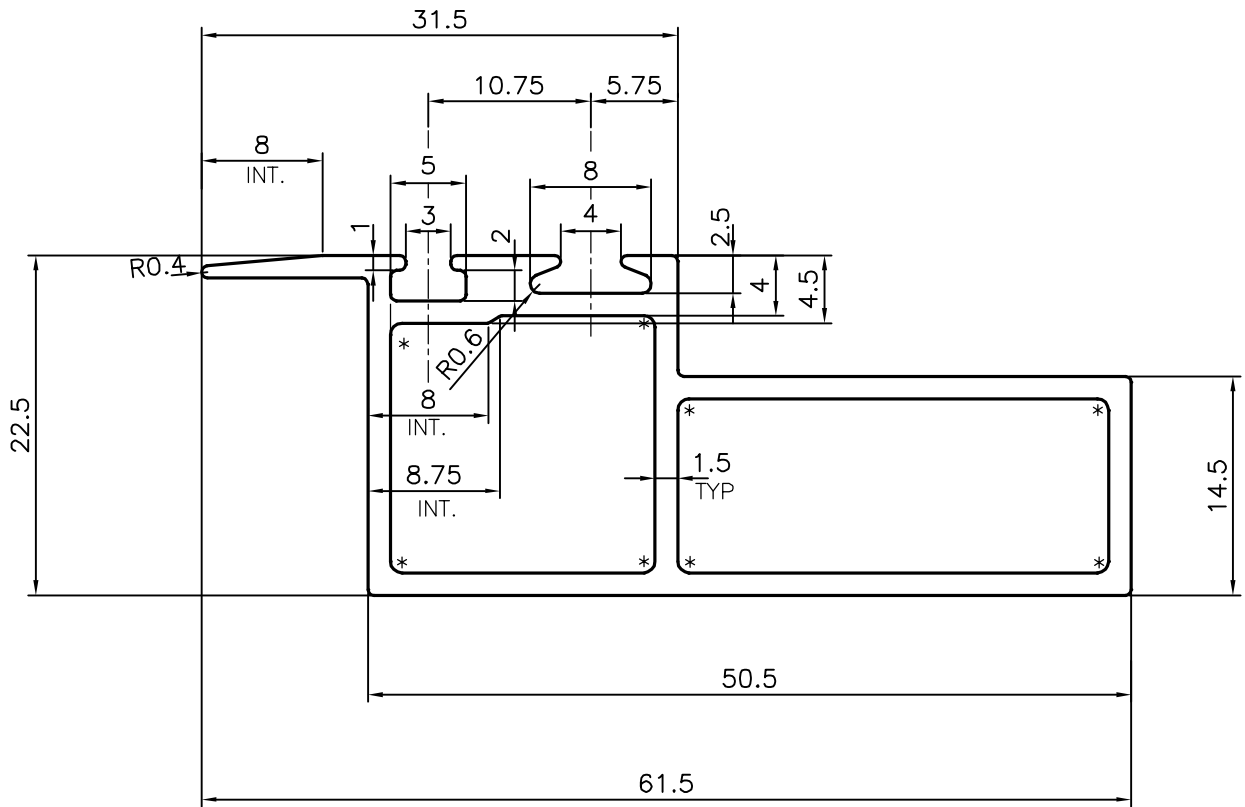
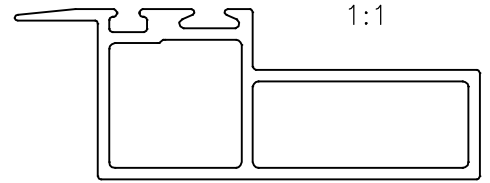

\* = 0.75 RADIUS (8 PLACES)



SYMBOL OF QUALITY  
AN ISO 9001 COMPANY

**JINDAL ALUMINIUM LTD.**  
BANGALORE-560073 (INDIA)

	NAME	DATE
DRAWN	J.P.KAUSHIK	28-10-2015
CHECKED		
APPROVED	S.S.GARG	09-11-2015
SCALE		2:1
AREA mm <sup>2</sup>		260.283
PERIMETER mm.		185.079
WEIGHT kg/m		0.703
DRAWING No.	SECTION No.	
P-15241-1	-	
S4726	S4726	
35987	35987	

1. ALL DIMENSIONS ARE IN mm.
2. ROUND OFF ALL SHARP CORNERS WITH 0.40 mm.
3. TOLERANCES WILL BE AS PER IS:6477-1983, UNLESS OTHERWISE SPECIFIED

PARTY'S NAME	A & G FACADES PVT. LTD., CHENNAI
PARTY'S DRAWING No.	AS PER AutoCAD DRAWING
ALLOY & TEMPER	HE9 WP
DESCRIPTION	CURTAIN WALL SECTION