

P-17692

35993

22709

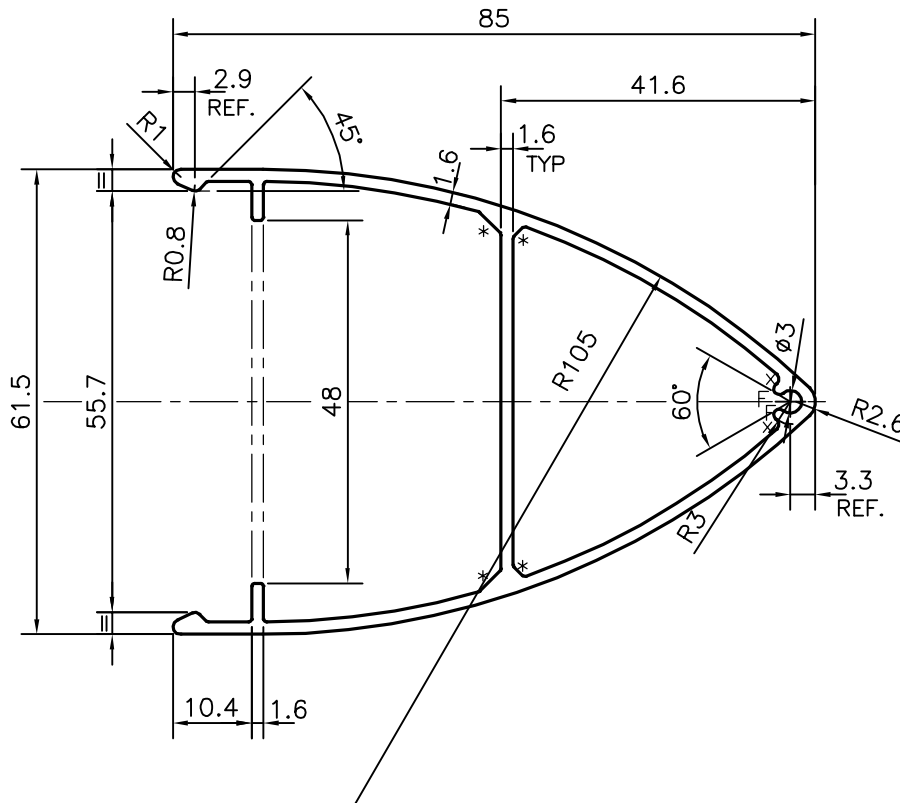
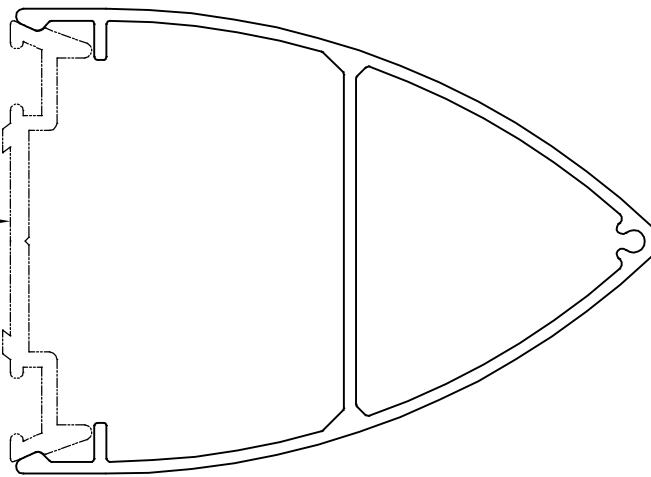

TOLERANCE CHART CD = CIRCUMSCRIBING CIRCLE

	CD ≤ 100	100 < CD ≤ 200	200 < CD < 300	300 < CD < 500
UPTO 10mm	±0.25	±0.30	±0.35	±0.40
10.0 - 25.0	±0.30	±0.40	±0.50	±0.60
25.0 - 50.0	±0.50	±0.60	±0.80	±0.90
50.0 - 100.0	±0.70	±0.90	±1.10	±1.30
100 - 150	-	±1.10	±1.30	±1.50
150 - 200	-	±1.3	±1.50	±1.80
200 - 300	-	-	±1.70	±2.10
300 - 450	-	-	-	±2.80

F = FULL RADIUS (2 PLACES)
 x = 0.8 RADIUS (2 PLACES)
 * = CHAMFER 2x45° (4 PLACES)



SYMBOL OF QUALITY
AN ISO 9001 COMPANY

JINDAL ALUMINIUM LTD.
 BANGALORE-560073 (INDIA)

	NAME	DATE
DRAWN	J.P.KAUSHIK	09-12-2017
CHECKED		
APPROVED	B.NATARAJA	19-12-2017
SCALE		1:1
AREA mm ²		410.765
PERIMETER mm.		344.74
WEIGHT kg/m		1.109
DRAWING No.	SECTION No.	
P-17692	-	
35993	35993	

1. ALL DIMENSIONS ARE IN mm.
2. ROUND OFF ALL SHARP CORNERS WITH 0.40 mm.
3. TOLERANCES WILL BE AS PER BS:EN-755-9 UNLESS OTHERWISE SPECIFIED

PARTY'S NAME	PRAYOSHA ENTERPRISES LTD., UGANDA
PARTY'S DRAWING No.	AS PER AutoCAD DRAWING
ALLOY & TEMPER	6063 T6
DESCRIPTION	CURTAIN WALL-COVER PLATE SECTION