

P-15619

S4853

35999

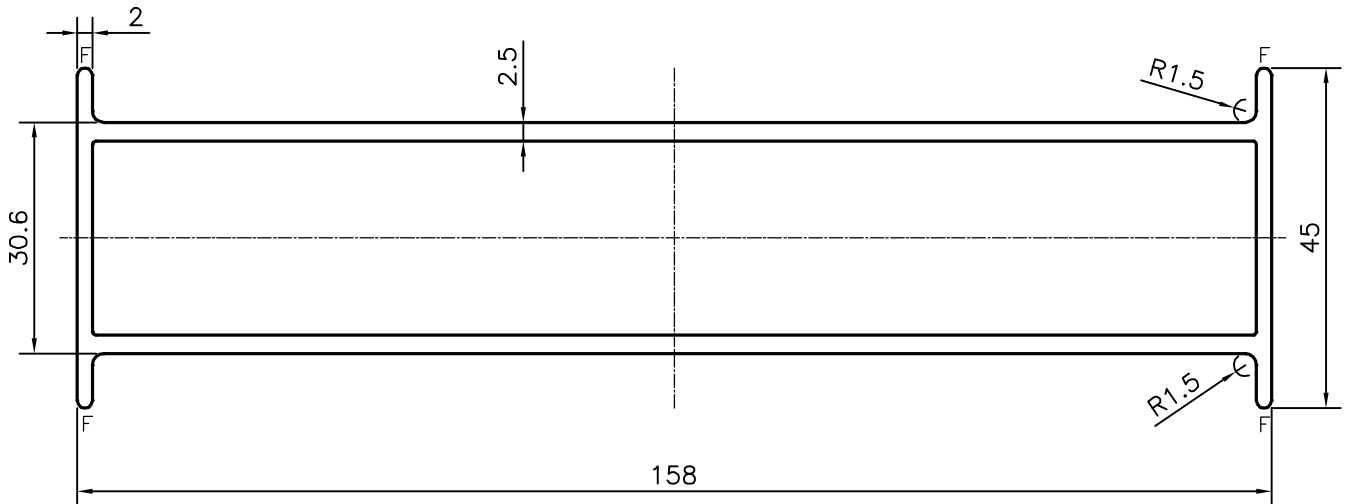

F = FULL RADIUS (4 PLACES)



SYMBOL OF QUALITY  
AN ISO 9001 COMPANY

**JINDAL ALUMINIUM LTD.**  
BANGALORE-560073 (INDIA)

	NAME	DATE
DRAWN	PARVESH	19-02-2016
CHECKED		
APPROVED	S.S.GARG	23-02-2016
SCALE		1:1
AREA mm <sup>2</sup>		950.352
PERIMETER mm.		428.791
WEIGHT kg/m		2.566
DRAWING No.	SECTION No.	
P-15619	-	
S4853	S4853	
35999	35999	

1. ALL DIMENSIONS ARE IN mm.
2. ROUND OFF ALL SHARP CORNERS WITH 0.40 mm.
3. TOLERANCES WILL BE AS PER IS:6477-1983 , UNLESS OTHERWISE SPECIFIED

PARTY'S NAME	D-GLAZE, GHAZIABAD
PARTY'S DRAWING No.	AS PER AUTOCAD DRAWING
ALLOY & TEMPER	6063 T6
DESCRIPTION	CURTAIN WALL SECTION-EXPANSION SLEEVE