

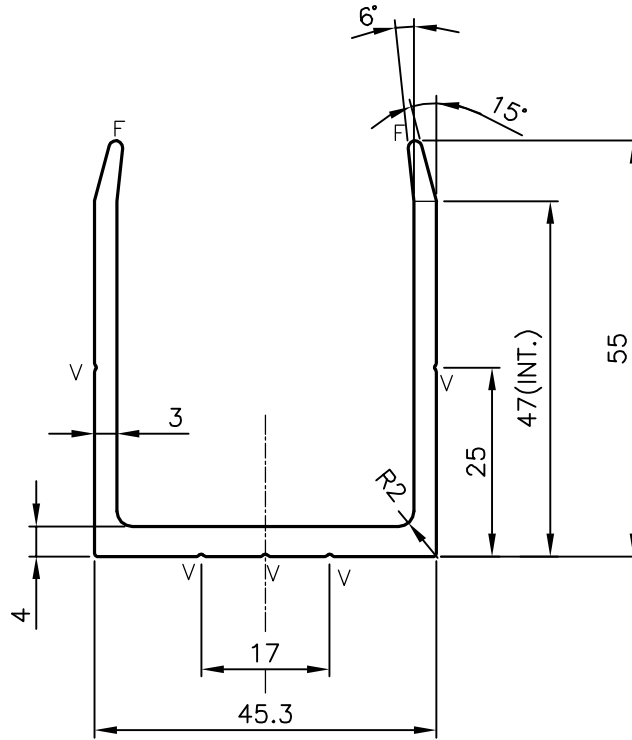

P-15616
S4860
36000



F = FULL RADIUS (2 PLACES)  
V = V GROOVE 0.3x90° ( 5 PLACES)

 SYMBOL OF QUALITY AN ISO 9001 COMPANY	<b>JINDAL ALUMINIUM LTD.</b> BANGALORE-560073 (INDIA)	NAME		DATE	
		DRAWN	J.P.KAUSHIK	19-02-2016	
1. ALL DIMENSIONS ARE IN mm. 2. ROUND OFF ALL SHARP CORNERS WITH 0.40 mm. 3. TOLERANCES WILL BE AS PER IS:3965-1981 UNLESS OTHERWISE SPECIFIED		CHECKED			
		APPROVED	S.S.GARG	24-03-2016	
PARTY'S NAME		D-GLAZE, GHAZIABAD		SCALE	1:1
		PARTY'S DRAWING No.		AS PER AutoCAD DRAWING	AREA mm <sup>2</sup>
ALLOY & TEMPER		6063 T6		PERIMETER mm.	298.133
		DESCRIPTION		MISC. SECTION	WEIGHT kg/m
				DRAWING No.	P-15616
				SECTION No.	-
				S4860	S4860
				36000	36000