

P-18107

36004

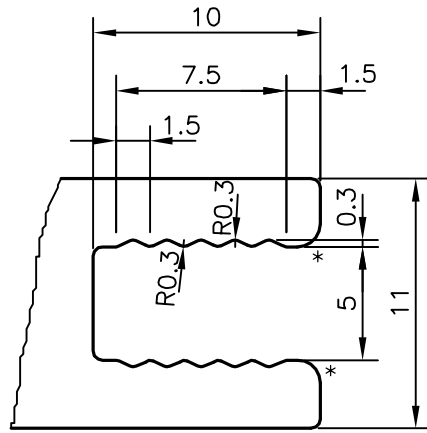

DETAIL OF "A"
SCALE 3:1

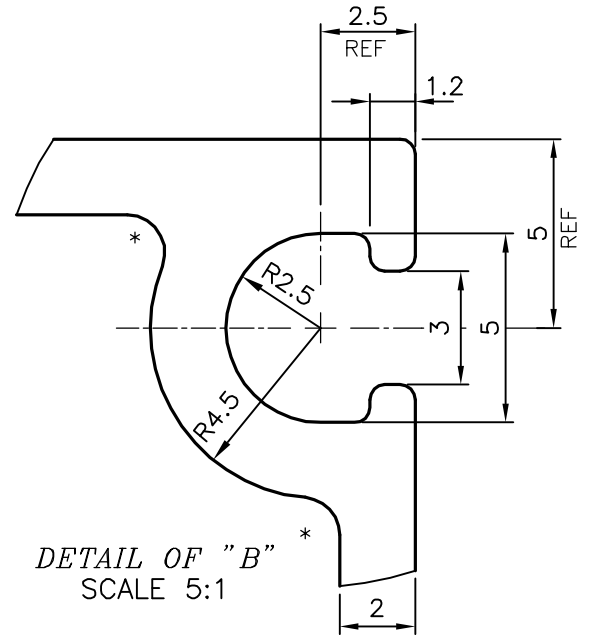

DETAIL OF "B"
SCALE 5:1

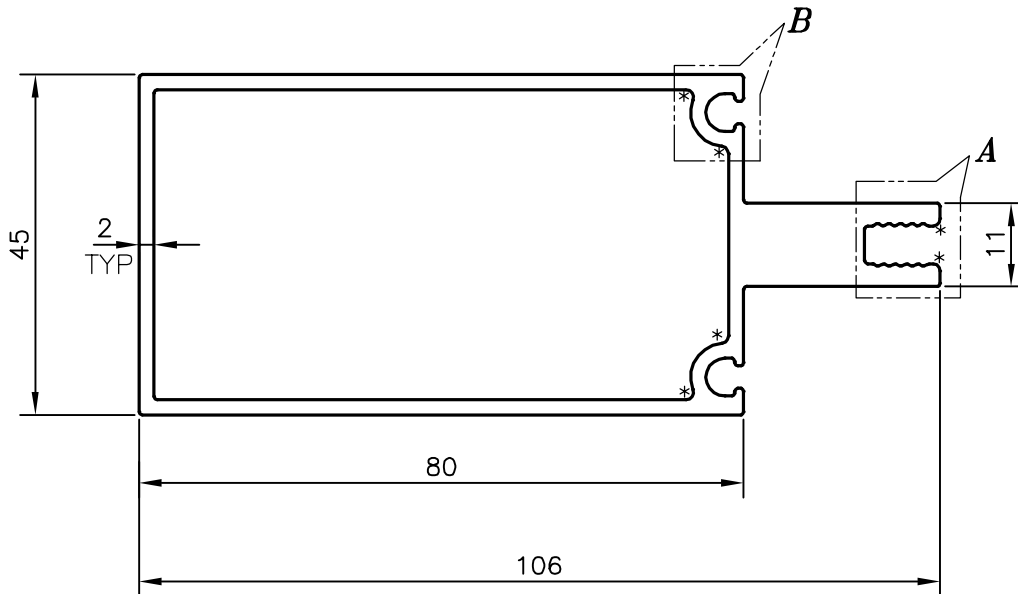

* = 1.0 RADIUS (6 PLACES)



SYMBOL OF QUALITY
AN ISO 9001 COMPANY

JINDAL ALUMINIUM LTD.
BANGALORE-560073 (INDIA)

	NAME	DATE
DRAWN	J.P.KAUSHIK	14-04-2018
CHECKED		
APPROVED	B.NATARAJA	23-04-2018
SCALE		1:1
AREA	mm ²	743.104
PERIMETER	mm.	342.384
WEIGHT	kg/m	2.006
DRAWING No.	SECTION No.	
P-18107	-	
36004	36004	

1. ALL DIMENSIONS ARE IN mm.
2. ROUND OFF ALL SHARP CORNERS WITH 0.40 mm.
3. TOLERANCES WILL BE AS PER IS:6477-1983 , UNLESS OTHERWISE SPECIFIED

PARTY'S NAME	GENERAL CATEGORY, MUMBAI MARKET
PARTY'S DRAWING No.	AS PER DRAWING
ALLOY & TEMPER	HE9 WP
DESCRIPTION	CURTAIN WALL SECTION