

P-15214-1
S4897
36006

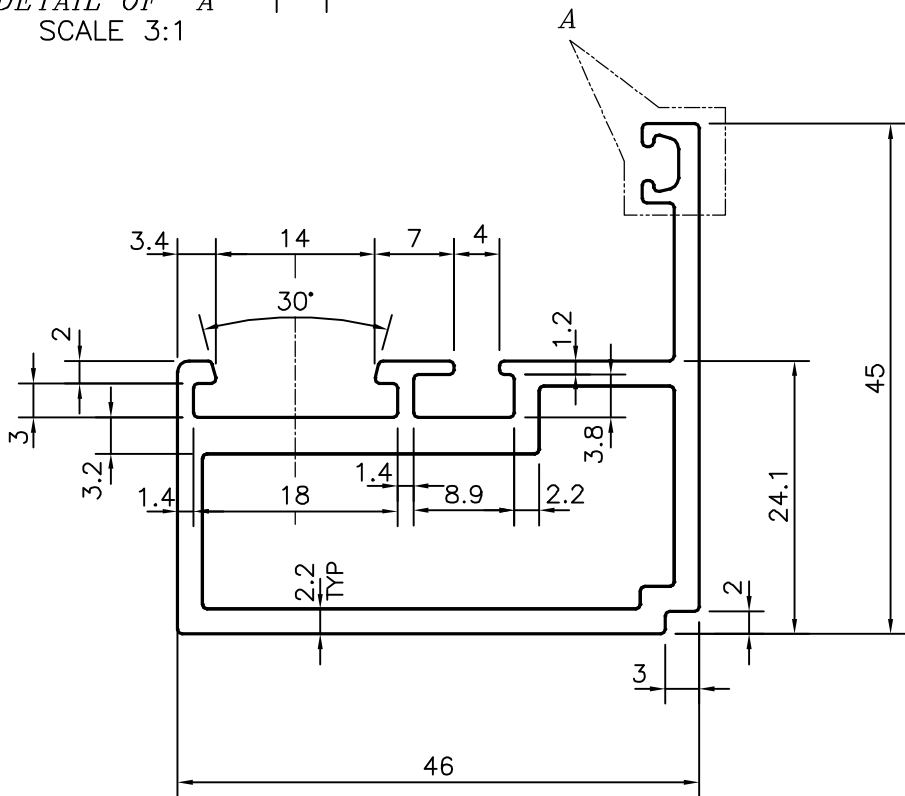
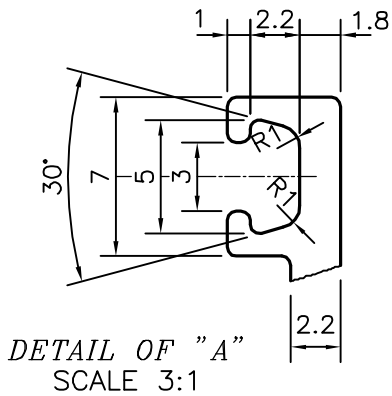
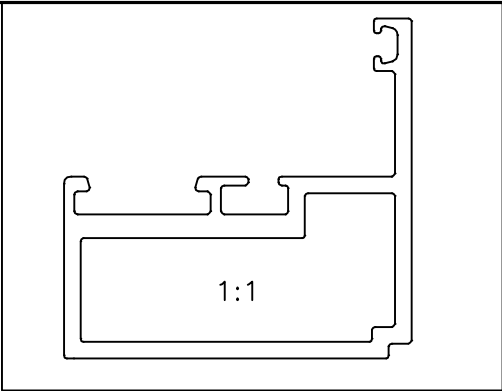

**JINDAL ALUMINIUM LTD.**  
BANGALORE-560073 (INDIA)

	NAME	DATE
DRAWN	J.P.KAUSHIK	04-03-2016
CHECKED		
APPROVED	S.S. GARG	04-04-2016
SCALE		1.5:1
AREA mm <sup>2</sup>		398.426
PERIMETER mm.		228.225
WEIGHT kg/m		1.076

1. ALL DIMENSIONS ARE IN mm.
2. ROUND OFF ALL SHARP CORNERS WITH 0.40 mm.
3. TOLERANCES WILL BE AS PER IS:6477-1983 UNLESS OTHERWISE SPECIFIED

PARTY'S NAME	AHLUWALIA CONTRACTS INDIA LTD., NEW DELHI
PARTY'S DRAWING No.	AS PER AutoCAD DRAWING
ALLOY & TEMPER	HE9 WP
DESCRIPTION	CURTAIN WALL SECTION

DRAWING No.	SECTION No.
P-15214-1	-
S4897	S4897
36006	36006