

P-11013
X1523
36026

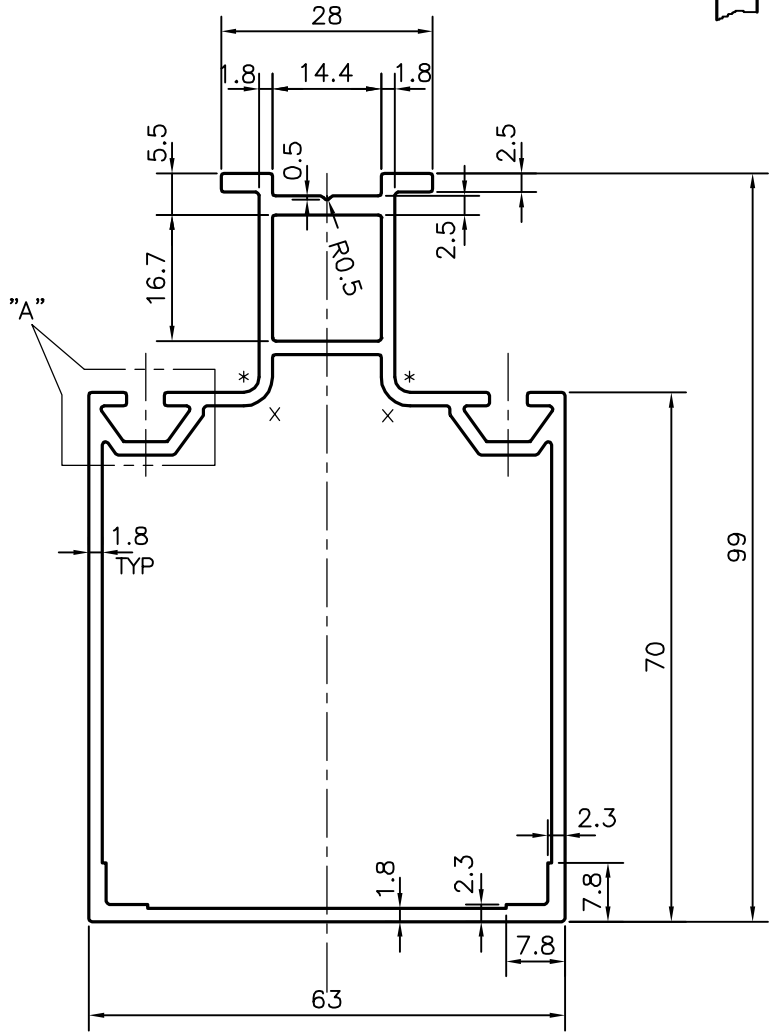

x = 3.8 RADIUS (2 PLACES)
* = 2.0 RADIUS (2 PLACES)

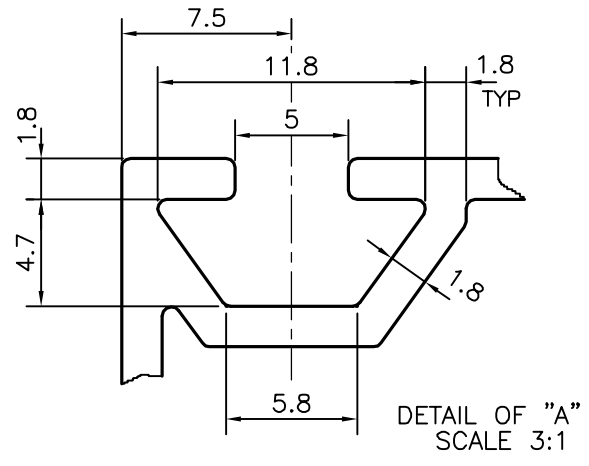

JINDAL ALUMINIUM LTD.
BANGALORE-560073 (INDIA)

	NAME	DATE
DRAWN	J.P.KAUSHIK	08-06-2011
CHECKED		
APPROVED	S.S.GARG	05-07-2011
SCALE		1:1
AREA mm ²		682.93
PERIMETER mm.		389.115
WEIGHT kg/m		1.844
DRAWING No.	SECTION No.	
P-11013	-	
X1523	X1523	
36026	36026	

1. ALL DIMENSIONS ARE IN mm.
2. ROUND OFF ALL SHARP CORNERS WITH 0.40 mm.
3. TOLERANCES WILL BE AS PER, IS:6477-1983 UNLESS OTHERWISE SPECIFIED

PARTY'S NAME	AMBICA ALUMINIUM CO., BANGALORE
PARTY'S DRAWING No.	5781
ALLOY & TEMPER	HE9 WP
DESCRIPTION	CURTAIN WALL SECTION