

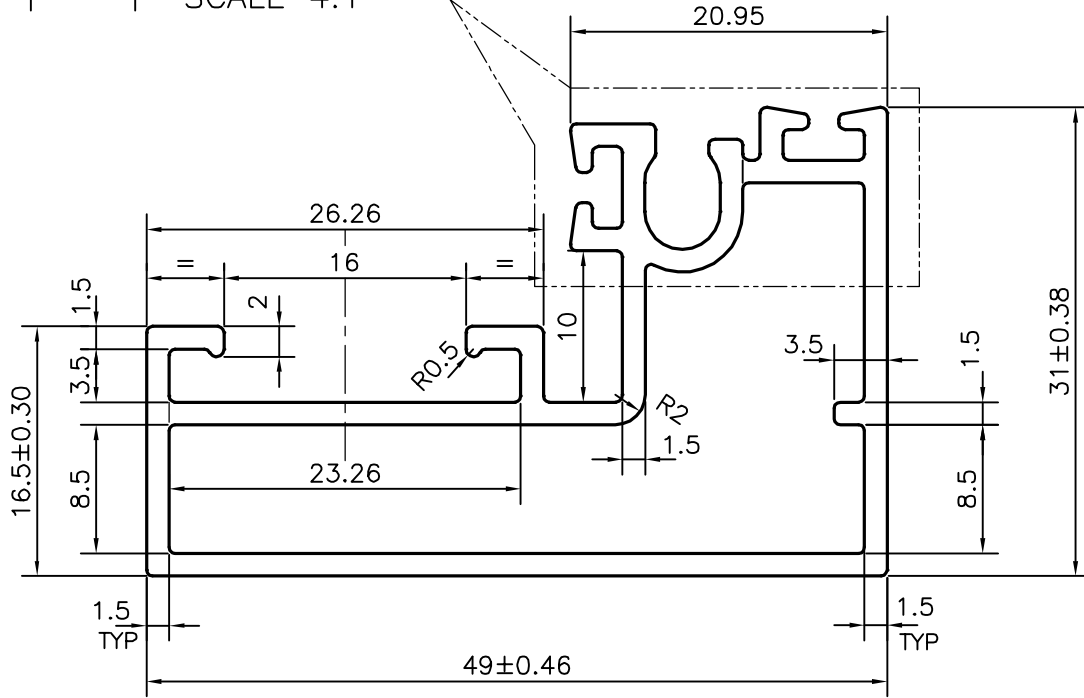

P-11365
X1565
36028

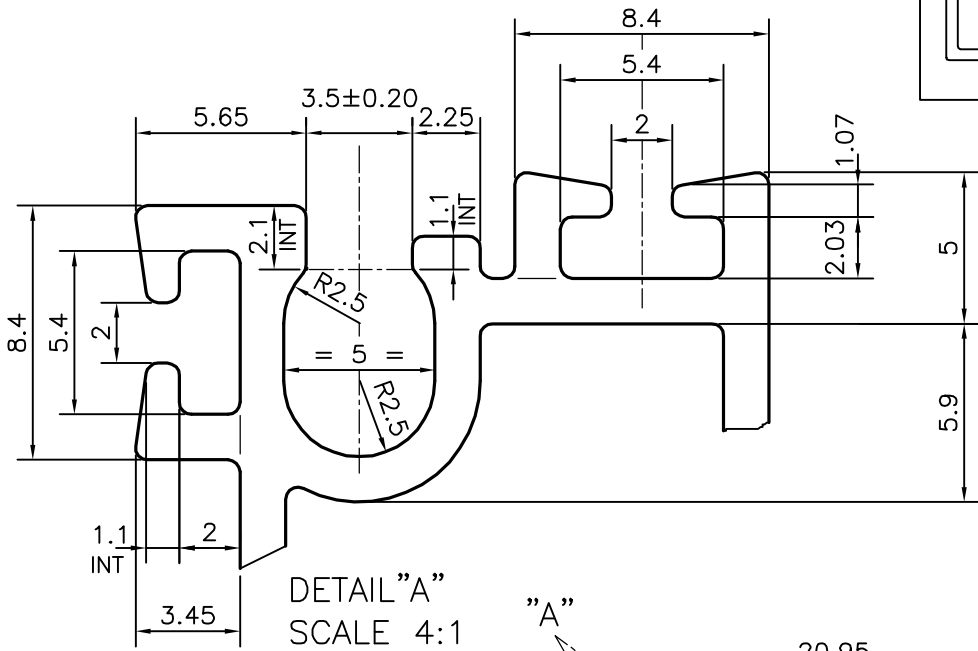
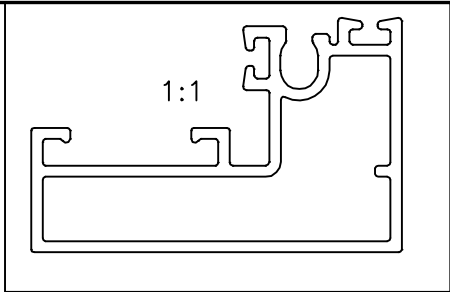

 SYMBOL OF QUALITY AN ISO 9001 COMPANY	<b>JINDAL ALUMINIUM LTD.</b> BANGALORE-560073 (INDIA)	NAME	DATE
		DRAWN	J.P.KAUSHIK
		CHECKED	
		APPROVED	S.S.GARG
		SCALE	2:1
		AREA mm <sup>2</sup>	293.894
		PERIMETER mm.	241.055
		WEIGHT kg/m	0.794
PARTY'S NAME	AMBICA ALUMINIUM COMPANY, BANGALORE	DRAWING No.	SECTION No.
PARTY'S DRAWING No.	AS PER DRAWING	P-11365	-
ALLOY & TEMPER	HE9 WP	X1565	X1565
DESCRIPTION	MISC. SECTION	36028	36028