

P-16403

S5127

36029

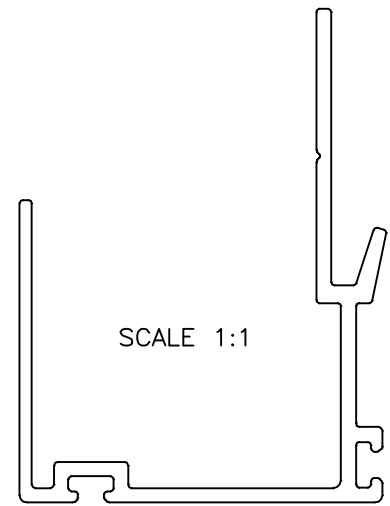
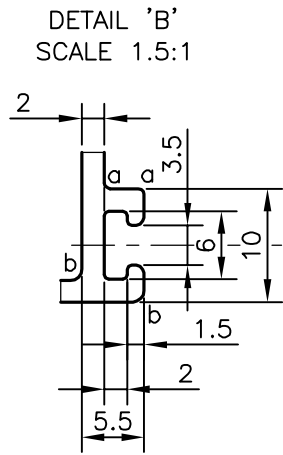

DETAIL 'A'
SCALE 1.5:1

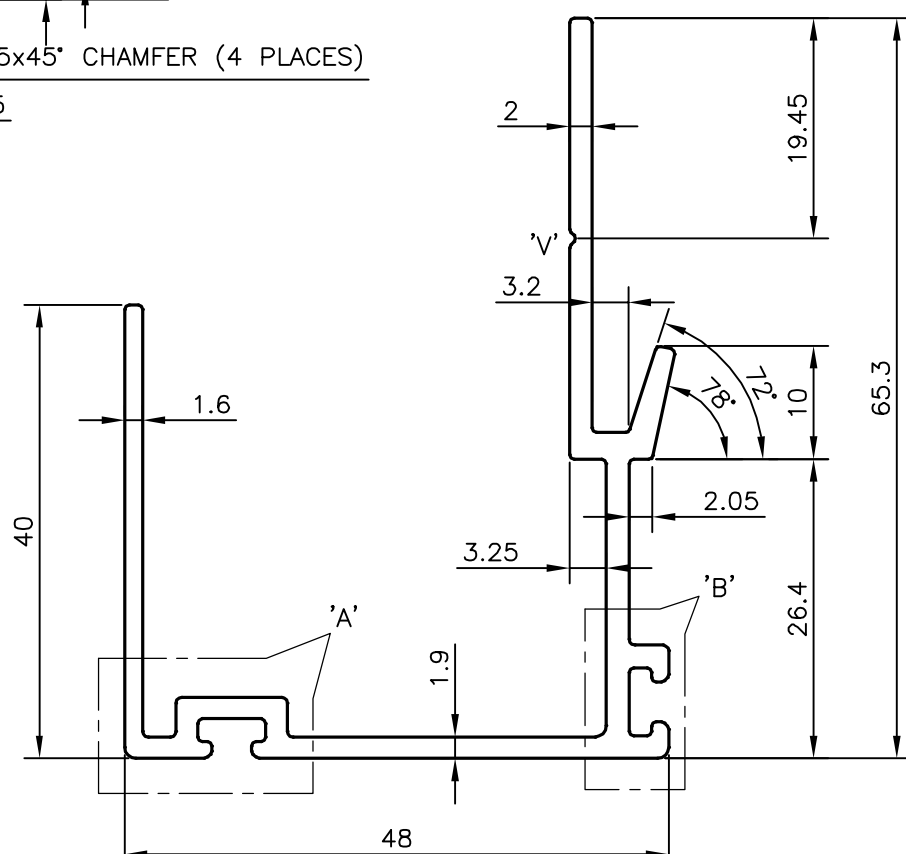
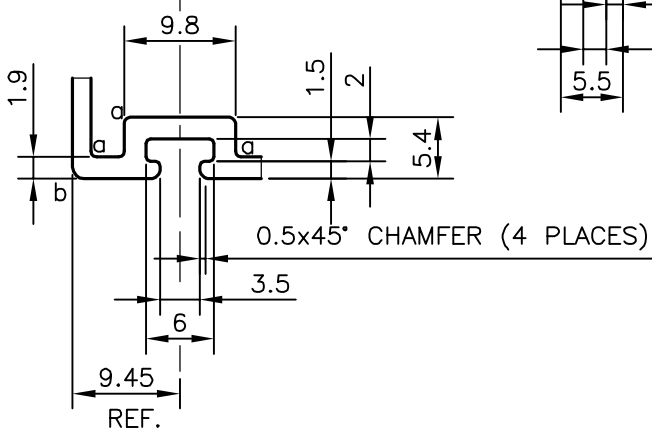

V : VEE GROOVE 0.5x90° (1 PLACE)

a : RADIUS 0.5 mm (5 PLACES)

b : RADIUS 1.0 mm (3 PLACES)



SYMBOL OF QUALITY
AN ISO 9001 COMPANY

JINDAL ALUMINIUM LTD.
BANGALORE-560073 (INDIA)

	NAME	DATE
DRAWN	KIRAN	29-09-2016
CHECKED		
APPROVED	B.NATARAJ	22-10-2016
SCALE		1.5:1
AREA mm ²		335.340
PERIMETER mm.		351.882
WEIGHT kg/m		0.905
DRAWING No.	SECTION No.	
P-16403		
S5127	S5127	
36029	36029	

1. ALL DIMENSIONS ARE IN mm.
2. ROUND OFF ALL SHARP CORNERS WITH 0.40 mm.
3. TOLERANCES WILL BE AS PER IS:3965-1981, UNLESS OTHERWISE SPECIFIED

PARTY'S NAME	GLOBAL SYNDICATE, BANGALORE
PARTY'S DRAWING No.	AS PER AutoCAD DRAWING
ALLOY & TEMPER	HE9 WP
DESCRIPTION	STAG JOINT FEMALE LOCKING