

P-16408

S5132

36034

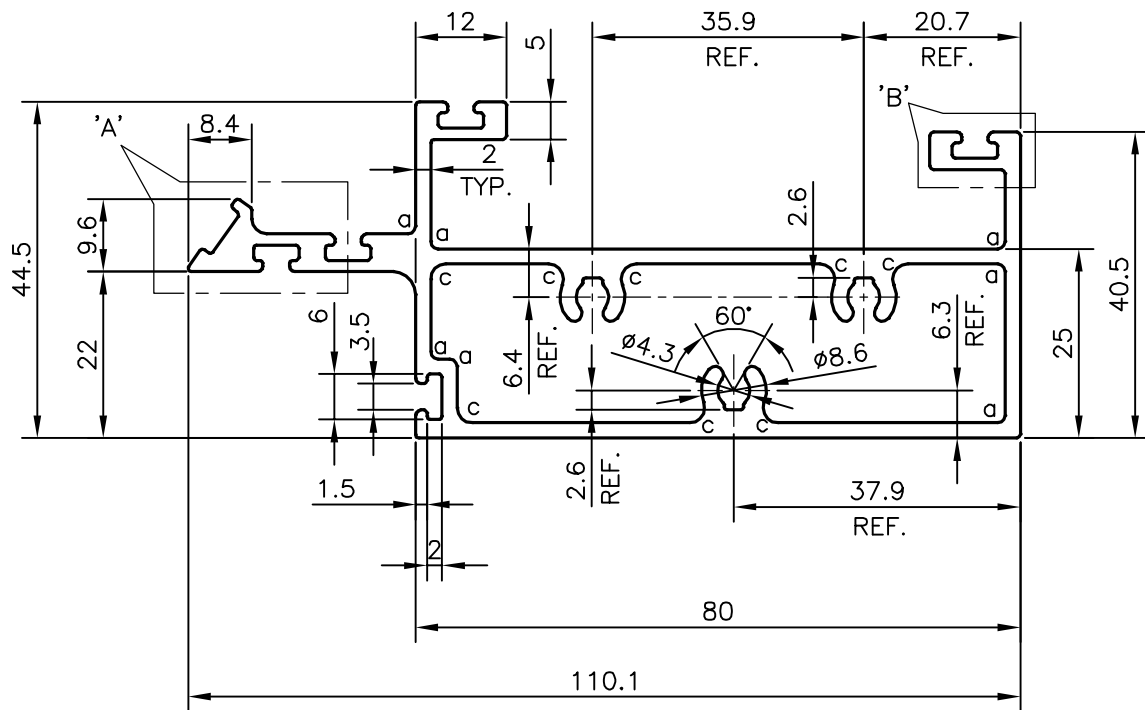

DETAIL 'A'

SCALE 2:1

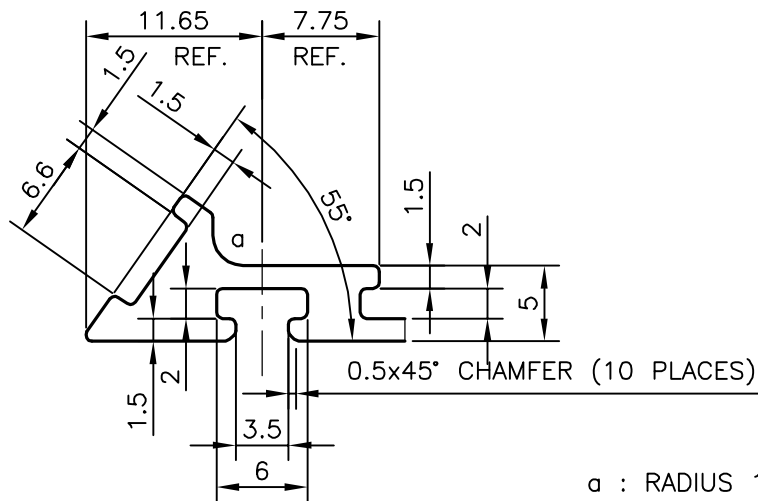

DETAIL 'B'

SCALE 2:1

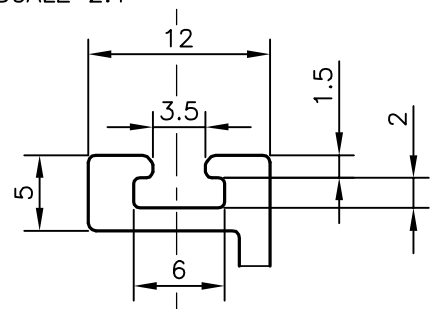

a : RADIUS 1.0 mm (7 places)
c : RADIUS 2.0 mm (9 places)



SYMBOL OF QUALITY
AN ISO 9001 COMPANY

JINDAL ALUMINIUM LTD.
BANGALORE-560073 (INDIA)

	NAME	DATE
DRAWN	KIRAN	29-09-2016
CHECKED		
APPROVED	B.NATARAJ	22-10-2016

1. ALL DIMENSIONS ARE IN mm.
2. ROUND OFF ALL SHARP CORNERS WITH 0.40 mm.
3. TOLERANCES WILL BE AS PER IS:6477-1983, UNLESS OTHERWISE SPECIFIED

SCALE	1:1
AREA mm ²	794.483
PERIMETER mm.	432.329
WEIGHT kg/m	2.145

PARTY'S NAME	GLOBAL SYNDICATE, BANGALORE	DRAWING No.	P-16408	SECTION No.	
PARTY'S DRAWING No.	AS PER AutoCAD DRAWING		S5132		S5132
ALLOY & TEMPER	HE9 WP		36034		36034
DESCRIPTION	STAG JOINT MALE-SILL				