

P-16410

S5134

36036

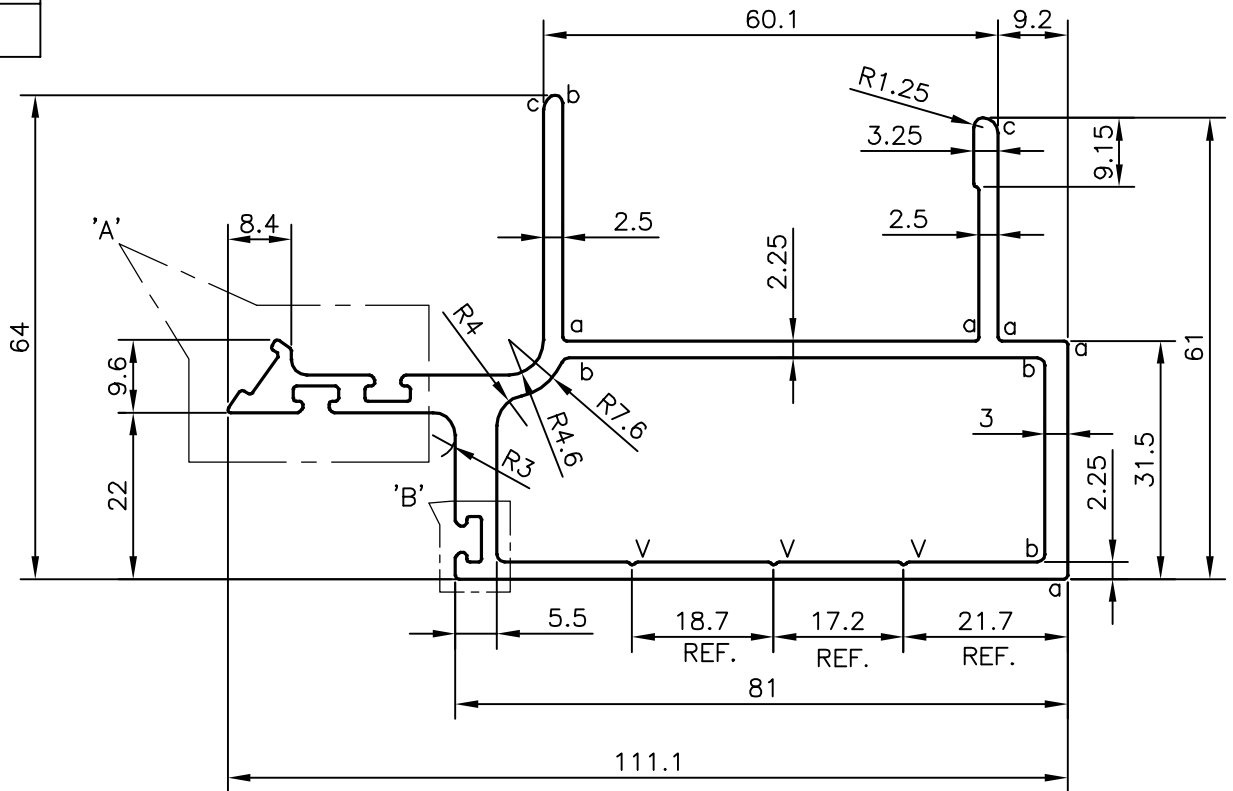

DETAIL 'A'

SCALE 2:1

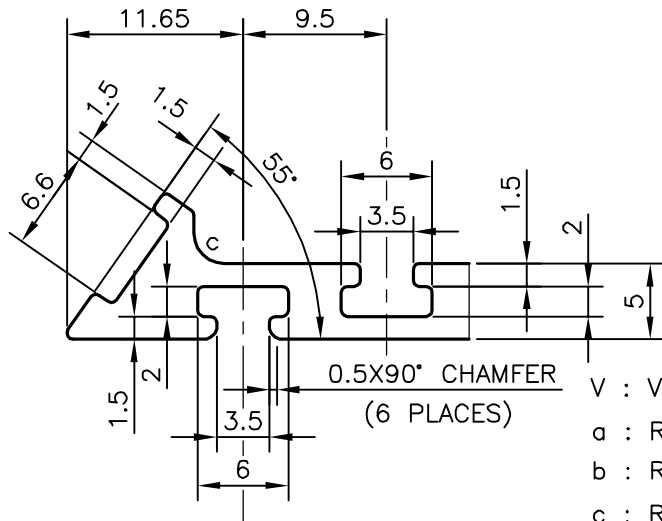

DETAIL 'B'

SCALE 2:1

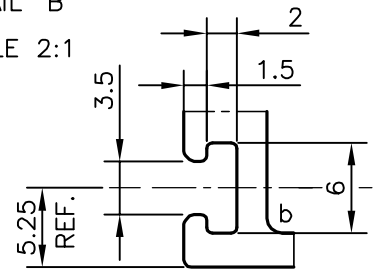

- V : VEE GROOVE 0.4x90° (3 PLACES)
- a : RADIUS 0.50mm (10 PLACES)
- b : RADIUS 1.0mm (10 PLACES)
- c : RADIUS 2.00 mm (2 PLACES)



SYMBOL OF QUALITY  
AN ISO 9001 COMPANY

**JINDAL ALUMINIUM LTD.**  
BANGALORE-560073 (INDIA)

	NAME	DATE
DRAWN	KIRAN	29-09-2016
CHECKED		
APPROVED	B.NATARAJ	22-10-2016

1. ALL DIMENSIONS ARE IN mm.
2. ROUND OFF ALL SHARP CORNERS WITH 0.40 mm.
3. TOLERANCES WILL BE AS PER IS:6477-1983, UNLESS OTHERWISE SPECIFIED

SCALE	1:1
AREA mm <sup>2</sup>	844.219
PERIMETER mm.	439.413
WEIGHT kg/m	2.279

PARTY'S NAME	GLOBAL SYNDICATE, BANGALORE	DRAWING No.	SECTION No.
PARTY'S DRAWING No.	AS PER AutoCAD DRAWING	P-16410	-
ALLOY & TEMPER	HE9 WP	S5134	S5134
		36036	36036
DESCRIPTION	MALE MULLION		