

P-16012

S5011

36039

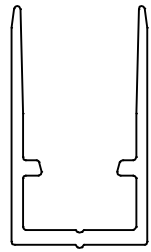

SCALE: - 1:1

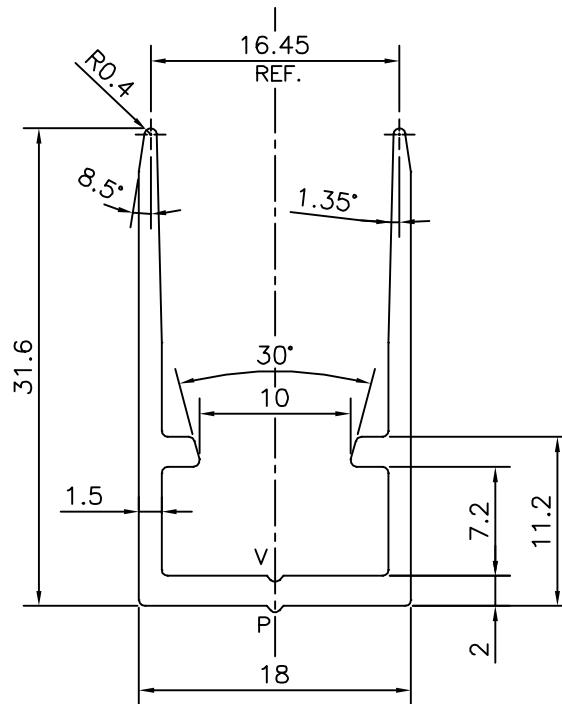

V = VEE GROOVE 0.4x90° (1 PLACE)
P = PIP 0.4x90° (1 PLACE)

TOLERANCES ON OVERALL WIDTHS & WIDTHS ACROSS FLATS OF BARS, & REGULAR SECTIONS

UPTO 6.40mm - ±0.20	UPTO 32.0mm - ±0.38	UPTO 120.0mm - ±0.85	1. STRAIGHTNESS=1.7mm/M 2. TWIST=1.7mm/M 3. ANGULARITY= ±2° 4. FLATNESS =0.007xWIDTH
UPTO 10.0mm - ±0.23	UPTO 50.0mm - ±0.46	UPTO 160.0mm - ±1.02	
UPTO 12.0mm - ±0.25	UPTO 60.0mm - ±0.53	UPTO 200.0mm - ±1.14	
UPTO 16.0mm - ±0.28	UPTO 80.0mm - ±0.69	UPTO 250.0mm - ±1.40	
UPTO 25.0mm - ±0.30	UPTO 100.0mm - ±0.75	UPTO 300.0mm - ±1.65	



SYMBOL OF QUALITY
AN ISO 9001 COMPANY

JINDAL ALUMINIUM LTD.
BANGALORE-560073 (INDIA)

	NAME	DATE
DRAWN	PARVESH	23-06-2016
CHECKED		
APPROVED	S.S. GARG	11-07-2016

- ALL DIMENSIONS ARE IN mm.
- ROUND OFF ALL SHARP CORNERS WITH 0.40 mm.
- TOLERANCES WILL BE AS PER IS:3965-1981, UNLESS OTHERWISE SPECIFIED

SCALE	2:1
AREA mm ²	128.096
PERIMETER mm.	164.352
WEIGHT kg/m	0.346

PARTY'S NAME	AHLUWALIA CONTRACTS (INDIA) LTD., MUMBAI	DRAWING No.	P-16012	SECTION No.	-
PARTY'S DRAWING No.	AS PER AUTOCAD DRAWING		S5011		S5011
ALLOY & TEMPER	6063 T6		36039		36039
DESCRIPTION	CURTAIN WALL SECTION				