

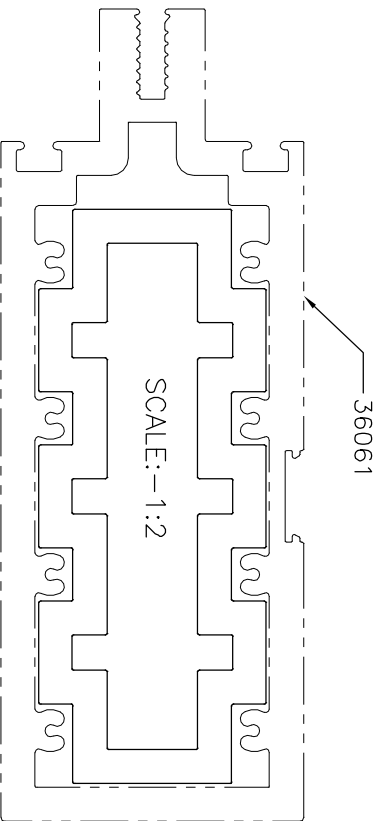

P-18966

36060

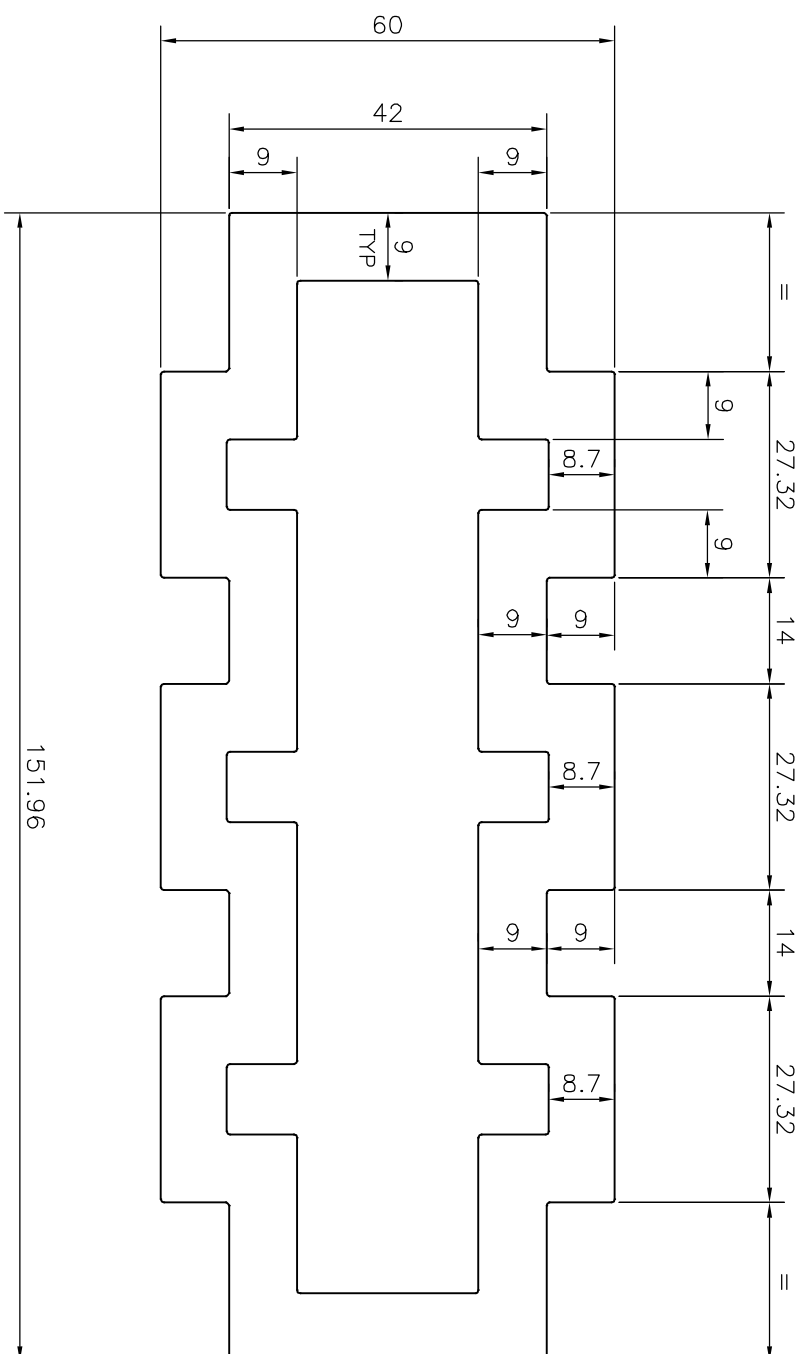

\* = RADIUS 1.0 (18 PLACES )  
 F = FULL RADIUS (16 PLACES )

 SYMBOL OF QUALITY AN ISO 9001 COMPANY		<b>JINDAL ALUMINIUM LTD.</b> BANGALORE-560073 (INDIA)	
1. ALL DIMENSIONS ARE IN mm. 2. ROUND OFF ALL SHARP CORNERS WITH 0.40 mm. 3. TOLERANCES WILL BE AS PER BS:EN-755-9 UNLESS OTHERWISE SPECIFIED		SCALE	1:1
PARTY'S NAME		AREA mm <sup>2</sup>	4122.504
PARTY'S DRAWING No.		PERIMETER mm.	491.113
ALLOY & TEMPER		WEIGHT kg/m	11.131
DESCRIPTION		DRAWING No.	SECTION No.
6063 T6		P-18966	-
MULLION SLEEVE SECTION		36060	36060