

P-18975-1

36062

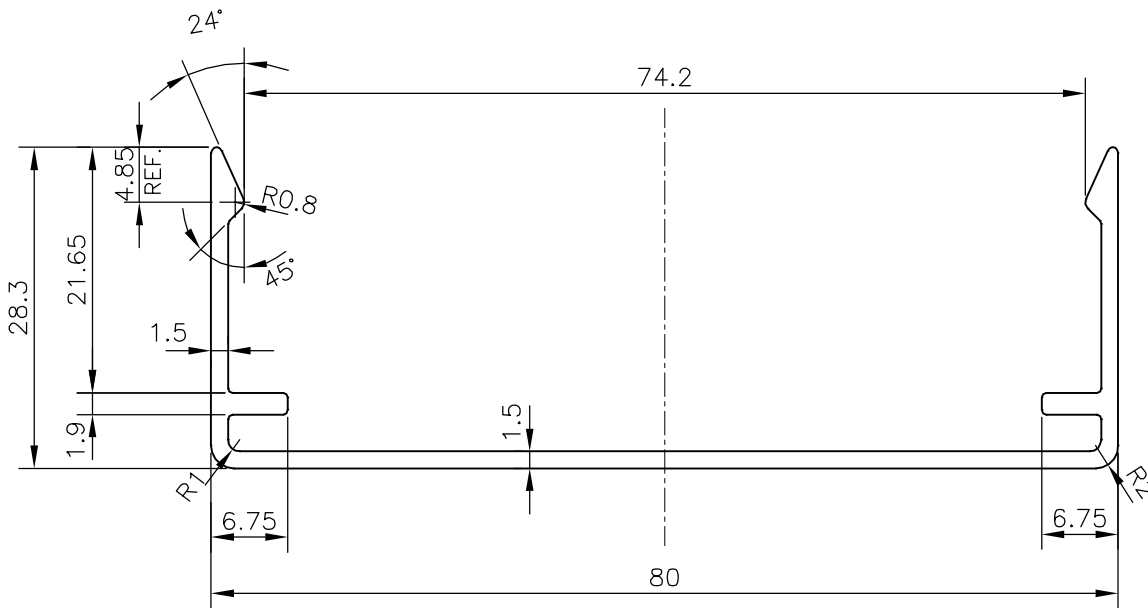
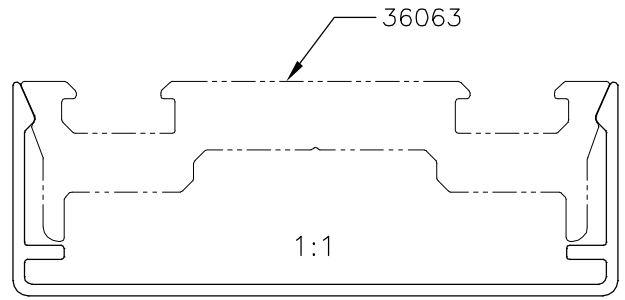

SYMBOL OF QUALITY
AN ISO 9001 COMPANY

JINDAL ALUMINIUM LTD.
BANGALORE-560073 (INDIA)

	NAME	DATE
DRAWN	J.P.KAUSHIK	29-12-2018
CHECKED		
APPROVED	B.NATARAJA	11-01-2019
SCALE		1.5:1
AREA mm ²		225.613
PERIMETER mm.		287.246
WEIGHT kg/m		0.609
DRAWING No.	SECTION No.	
P-18975-1	-	
36062	36062	

1. ALL DIMENSIONS ARE IN mm.
2. ROUND OFF ALL SHARP CORNERS WITH 0.40 mm.
3. TOLERANCES WILL BE AS PER BS:EN-755-9 , UNLESS OTHERWISE SPECIFIED

PARTY'S NAME	GLASS & MIRROR FIJI LTD., FIJI
PARTY'S DRAWING No.	CKU2781
ALLOY & TEMPER	6063 T6
DESCRIPTION	COVER CAP SECTION