

P-18976-1

36063

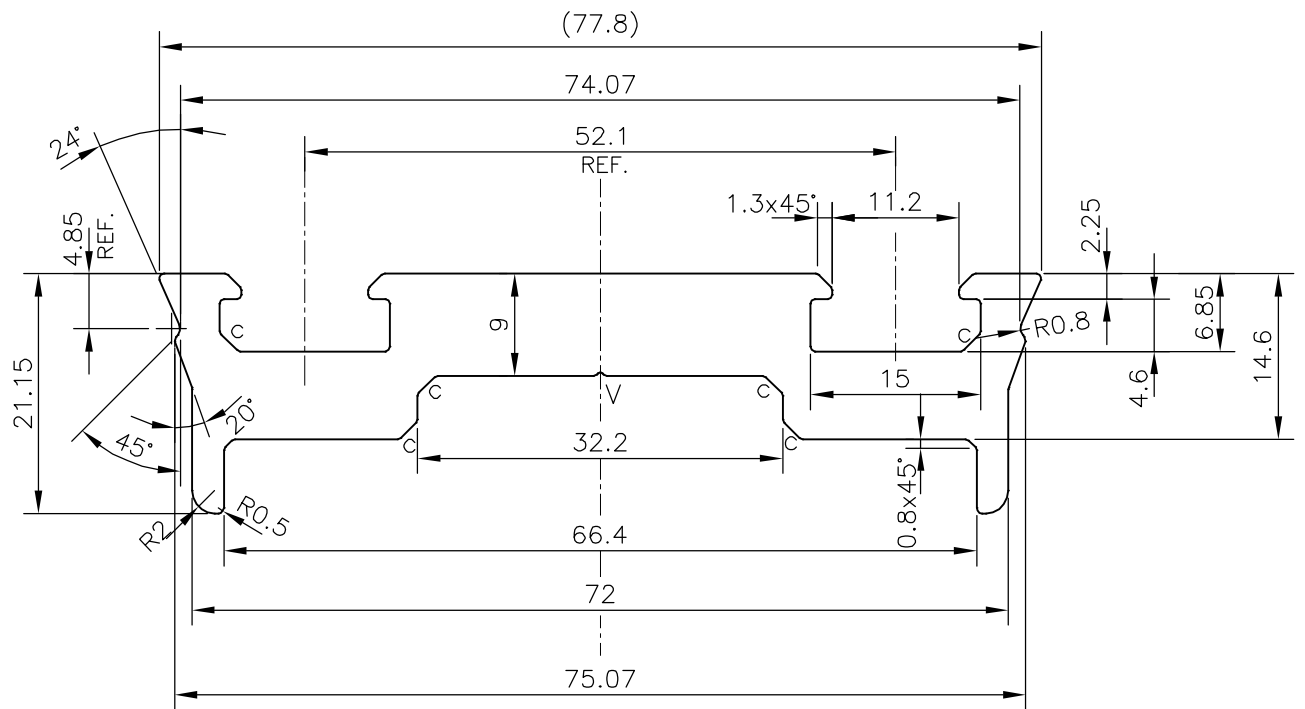

V = V GROOVE 0.3x90° (1 PLACE)
 c = CHAMFER 1.6x45° (6 PLACES)

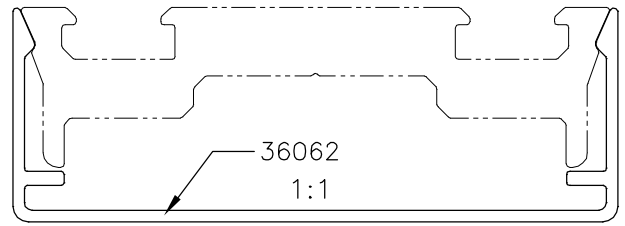

SYMBOL OF QUALITY
 AN ISO 9001 COMPANY

JINDAL ALUMINIUM LTD.
 BANGALORE-560073 (INDIA)

	NAME	DATE
DRAWN	J.P.KAUSHIK	29-12-2018
CHECKED		
APPROVED	B.NATARAJA	11-01-2019
SCALE		1.5:1
AREA mm ²		745.83
PERIMETER mm.		246.589
WEIGHT kg/m		2.014
DRAWING No.	SECTION No.	
P-18976-1	-	
36063	36063	

1. ALL DIMENSIONS ARE IN mm.
2. ROUND OFF ALL SHARP CORNERS WITH 0.40 mm.
3. TOLERANCES WILL BE AS PER BS:EN-755-9 , UNLESS OTHERWISE SPECIFIED

PARTY'S NAME	GLASS & MIRROR FIJI LTD., FIJI
PARTY'S DRAWING No.	CKU2782
ALLOY & TEMPER	6063 T6
DESCRIPTION	PRESSURE PLATE