

P-16165-1

X2042

36072

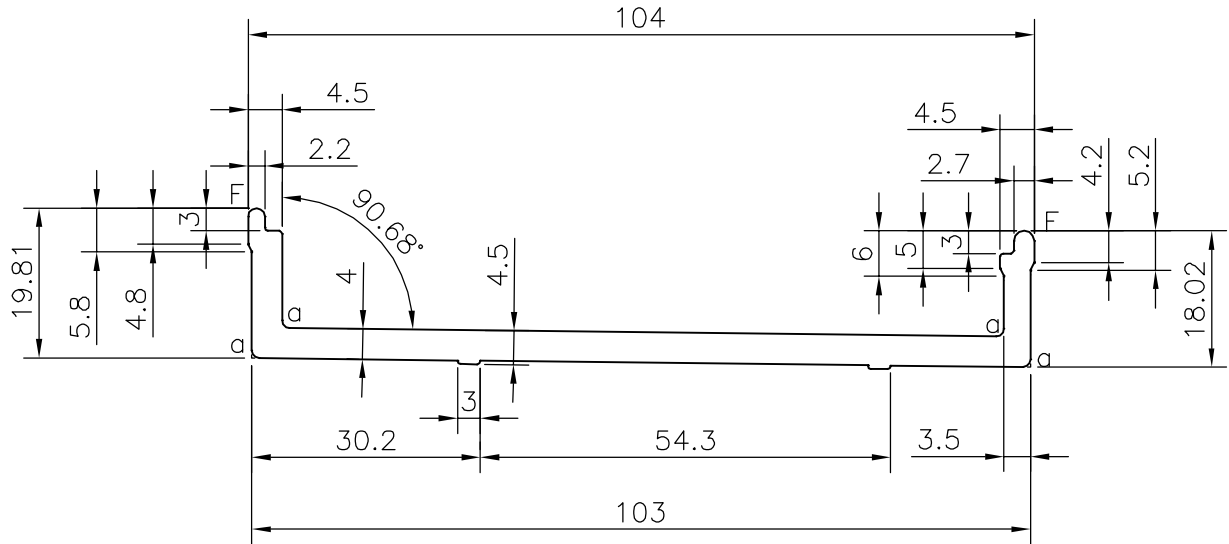

36070

a: 1.0 RADIUS(4 PLACES)  
 F: FULL RADIUS(2 PLACES)

SCALE 1:1



SYMBOL OF QUALITY  
 AN ISO 9001 COMPANY

**JINDAL ALUMINIUM LTD.**  
 BANGALORE-560073 (INDIA)

	NAME	DATE
DRAWN	KIRAN	10-08-2016
CHECKED		
APPROVED	S.S. GARG	12-08-2016
SCALE		1:1
AREA mm <sup>2</sup>		521.310
PERIMETER mm.		272.279
WEIGHT kg/m		1.407
DRAWING No.	SECTION No.	
P-16165-1	-	
X2042	X2042	
36072	36072	

1. ALL DIMENSIONS ARE IN mm. 2. ROUND OFF ALL SHARP CORNERS WITH 0.40 mm. 3. TOLERANCES WILL BE AS PER IS:3965-1981, UNLESS OTHERWISE SPECIFIED	
PARTY'S NAME	HATIM GLAZING & CLADDING PVT. LTD., MUMBAI
PARTY'S DRAWING No.	AS PER AutoCAD DRAWING
ALLOY & TEMPER	HE9 WP
DESCRIPTION	CURTAIN WALL SECTION