

P-18884

S6048

36087

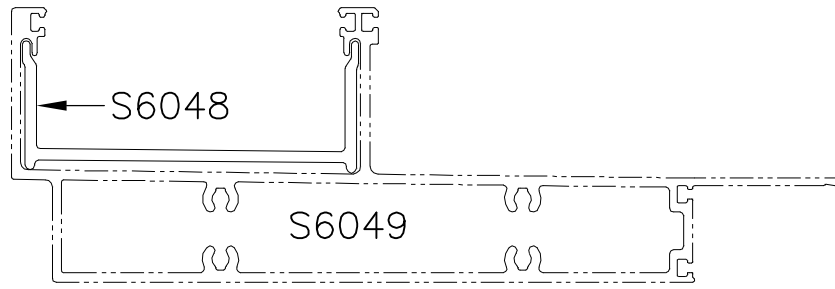

SCLAE1:2

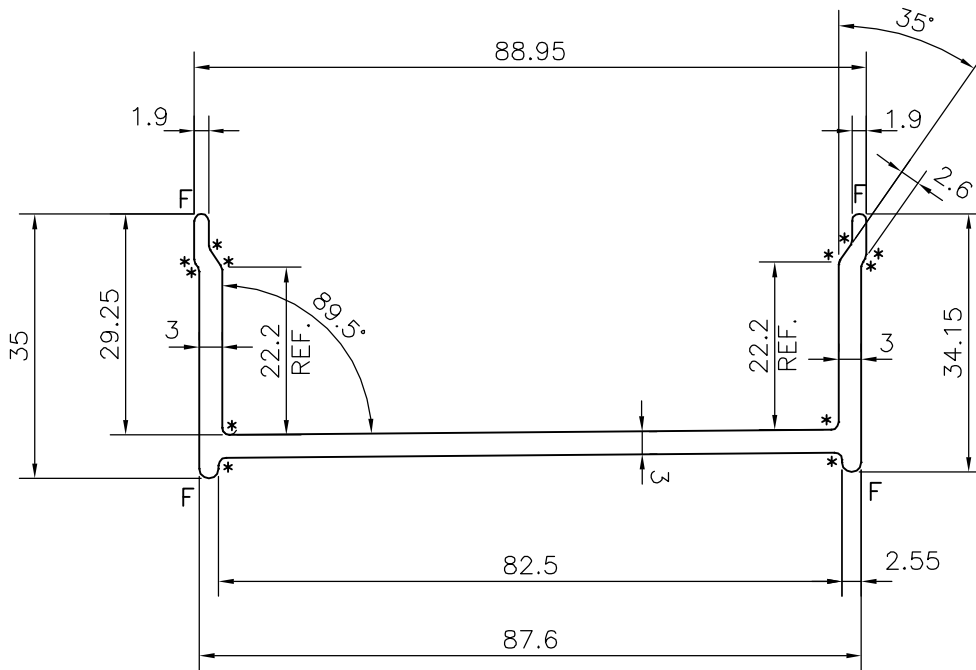

\* = R1 mm (12 PLACES)

F = FULL RADIUS (4 PLACES)



SYMBOL OF QUALITY  
AN ISO 9001 COMPANY

**JINDAL ALUMINIUM LTD.**  
BANGALORE-560073 (INDIA)

	NAME	DATE
DRAWN	DARPAN	19-11-2018
CHECKED		
APPROVED	B.NATARAJA	01-12-2018
SCALE		1:1
AREA mm <sup>2</sup>		437.977
PERIMETER mm.		301.156
WEIGHT kg/m		1.183
DRAWING No.	SECTION No.	
P-18884	-	
S6048	S6048	
36087	36087	

1. ALL DIMENSIONS ARE IN mm.
2. ROUND OFF ALL SHARP CORNERS WITH 0.40 mm.
3. TOLERANCES WILL BE AS PER IS:3965-1981 , UNLESS OTHERWISE SPECIFIED

PARTY'S NAME	GLOBAL SYNDICATE, BANGALORE
PARTY'S DRAWING No.	AS PER DRAWING
ALLOY & TEMPER	6063 T6
DESCRIPTION	GUTTER SLEEVE SECTION