

P-16860
S5331
36105

DRAWN MANUALLY TO FIT EACH OTHER AS SHOWN

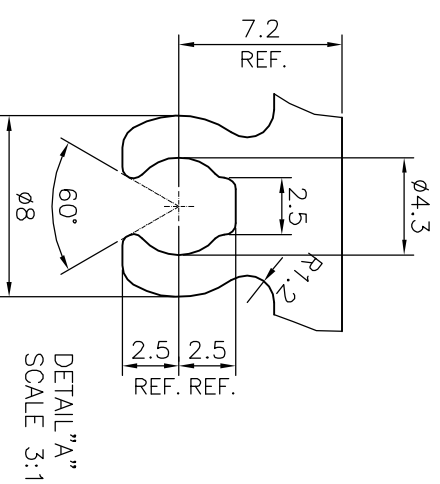
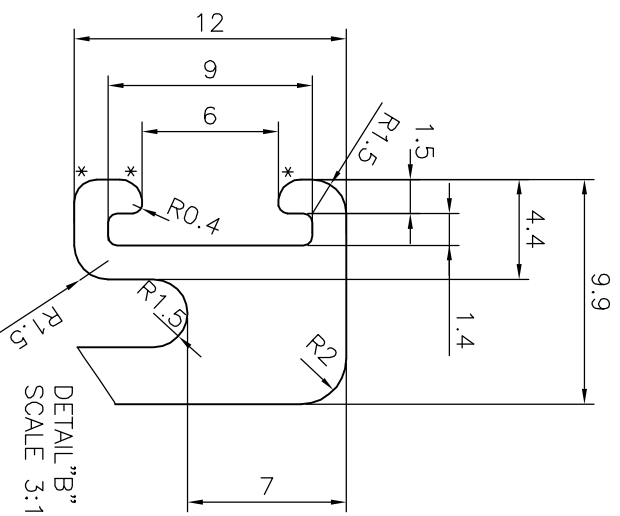
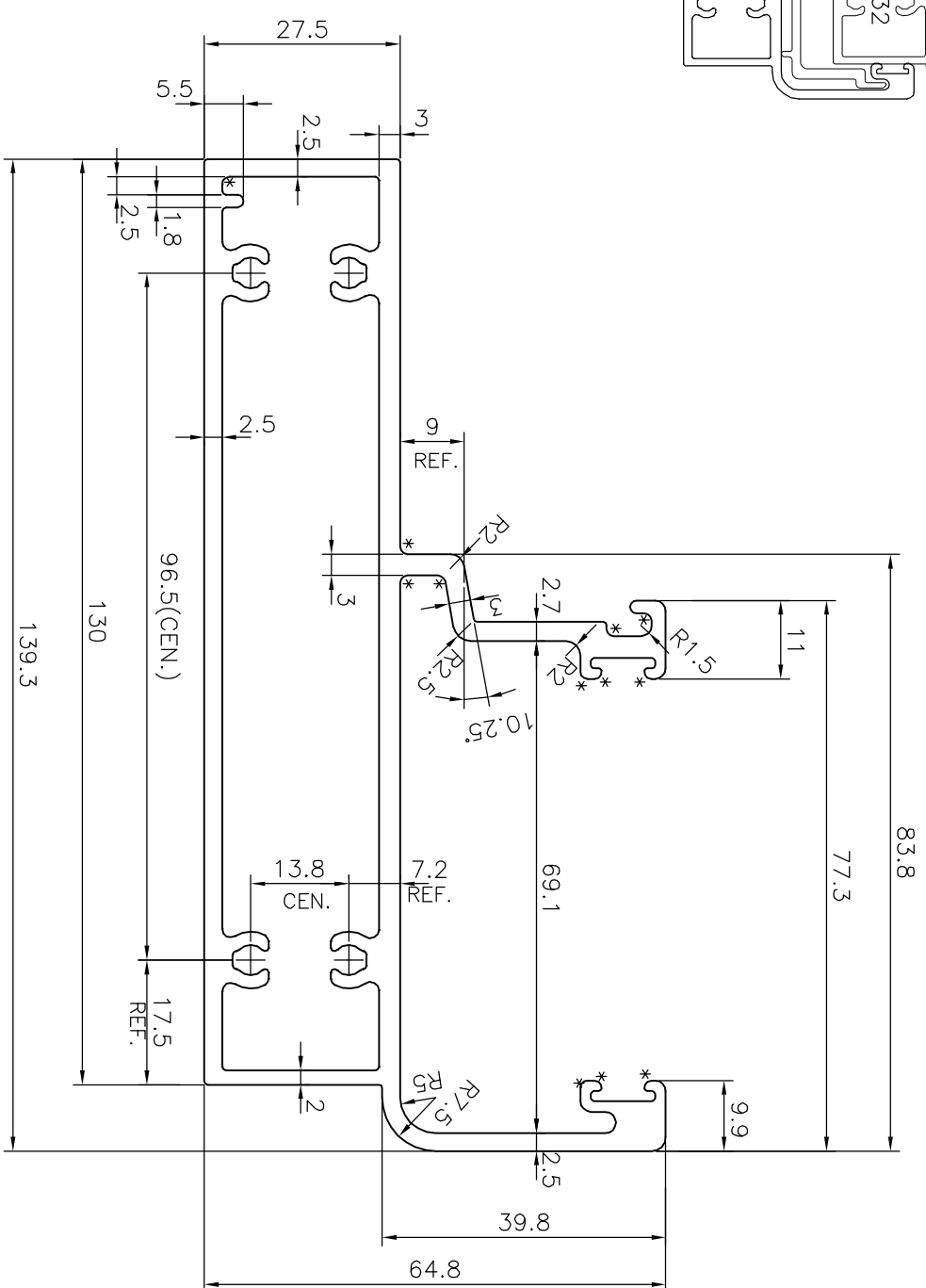
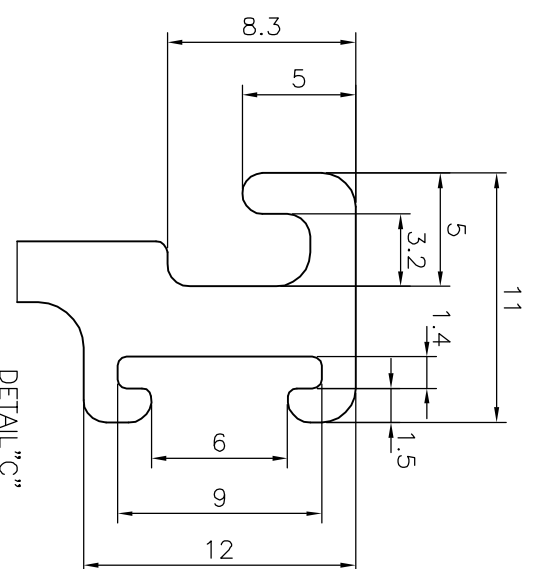
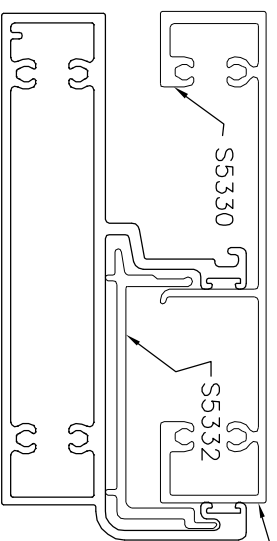

* = RADIUS 1.0 (12 PLACES)

TOLERANCES ON OVERALL DIMENSIONS OF HOLLOW SECTIONS

UPTO 20.0mm - ±0.30	UPTO 80.0mm - ±0.70	UPTO 180.0mm - ±1.27
UPTO 30.0mm - ±0.38	UPTO 100.0mm - ±0.80	UPTO 200.0mm - ±1.40
UPTO 40.0mm - ±0.45	UPTO 120.0mm - ±0.90	UPTO 225.0mm - ±1.52
UPTO 50.0mm - ±0.52	UPTO 140.0mm - ±1.00	
UPTO 60.0mm - ±0.60	UPTO 160.0mm - ±1.14	

1. STRAIGHTNESS=1.7mm/M
2. TWIST=1.7mm/M
3. ANGULARITY= ±2°
4. FLATNESS =0.006xWIDTH

 <p>JINDAL ALUMINIUM LTD. BANGALORE-560073 (INDIA)</p>		<p>1. ALL DIMENSIONS ARE IN mm. 2. ROUND OFF ALL SHARP CORNERS WITH 0.40 mm. 3. TOLERANCES WILL BE AS PER IS:6477-1983 UNLESS OTHERWISE SPECIFIED</p>
--	--	---

PARTY'S NAME	OMKAR REALTORS & DEVELOPERS PVT. LTD., MUMBAI	WEIGHT kg/m	3.429
PARTY'S DRAWING No.	AP-1716	DRAWING No.	
ALLOY & TEMPER	6063 T6	SECTION No.	
DESCRIPTION	CURTAIN WALL SECTION		

DRAWN	J.P.KAUSHIK	DATE	01-03-2017
CHECKED			
APPROVED	B.NATARAU		23-03-2017
SCALE			1:1
AREA	mm ²		1269.959
PERIMETER	mm.		551.631