

P-17014

S5383

36120

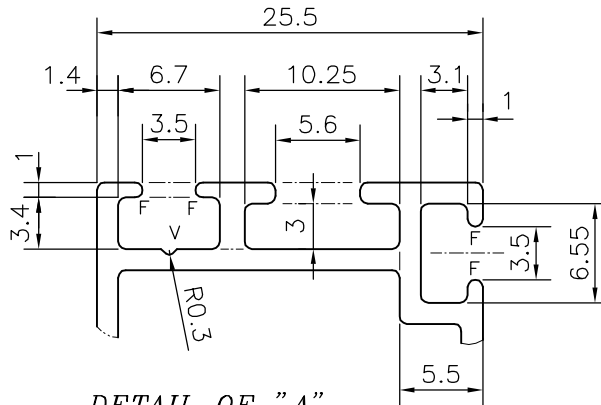
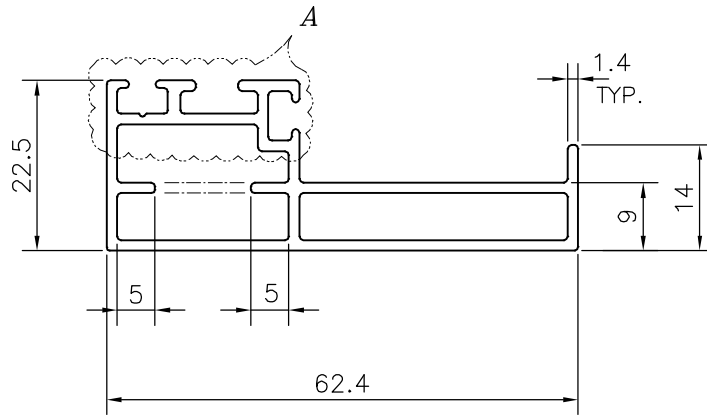

DETAIL OF "A"
SCALE :- 2:1

V = VEE GROOVE 0.4x90° (1 PLACE)
F = FULL RADIUS (4 PLACES)



SYMBOL OF QUALITY
AN ISO 9001 COMPANY

JINDAL ALUMINIUM LTD.
BANGALORE-560073 (INDIA)

	NAME	DATE
DRAWN	PARVESH	26-04-2017
CHECKED		
APPROVED	B.NATARAJA	28-04-2017
SCALE		1:1
AREA mm ²		285.298
PERIMETER mm.		220.881
WEIGHT kg/m		0.770
DRAWING No.	SECTION No.	
P-17014	-	
S5383	S5383	
36120	36120	

1. ALL DIMENSIONS ARE IN mm.
2. ROUND OFF ALL SHARP CORNERS WITH 0.50 mm.
3. TOLERANCES WILL BE AS PER IS:6477-1983, UNLESS OTHERWISE SPECIFIED

PARTY'S NAME	GAZEL ARCHITECTURES PVT.LTD., CHENNAI
PARTY'S DRAWING No.	MODIFIED OF SECTION No. 35820
ALLOY & TEMPER	HE9 WP
DESCRIPTION	CURTAIN WALL SECTION-SUBFRAME-2