

P-19838

36122

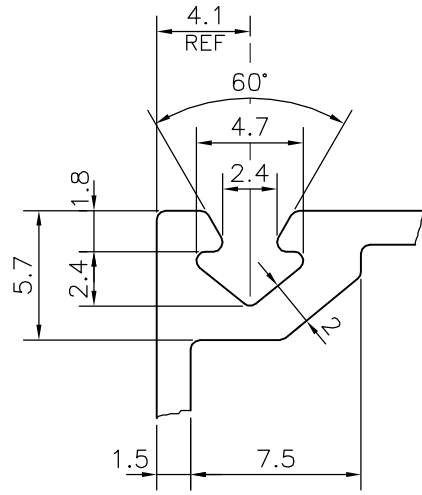

DETAIL OF "B"
SCALE 3:1

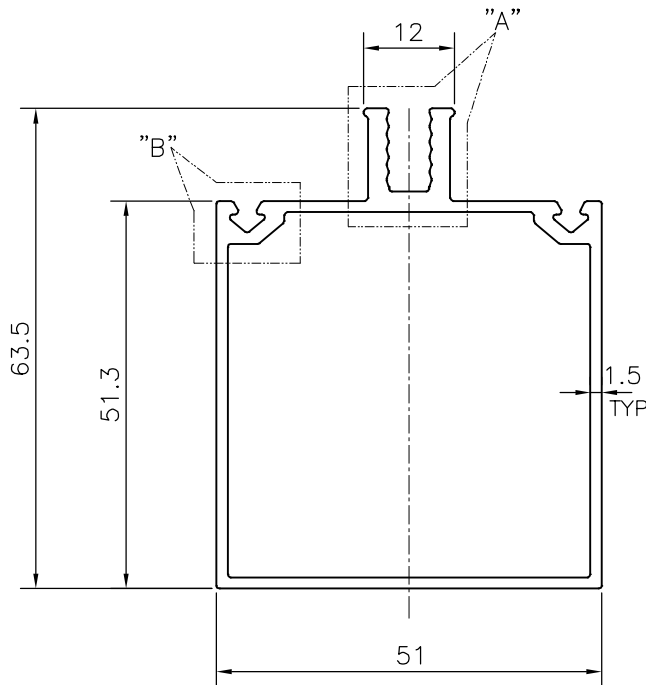
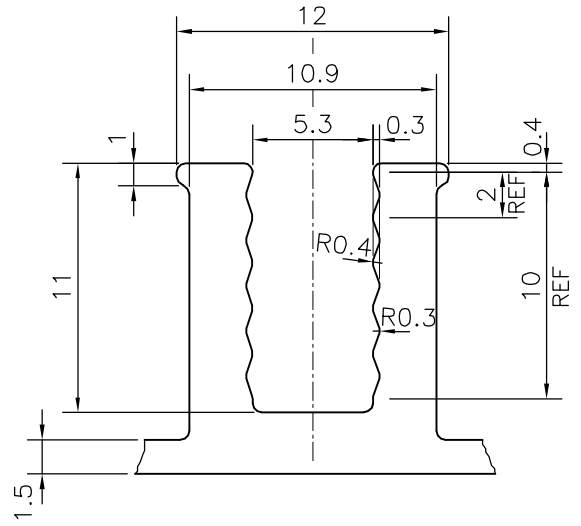

SYMBOL OF QUALITY
AN ISO 9001 COMPANY

JINDAL ALUMINIUM LTD.
BANGALORE-560073 (INDIA)

	NAME	DATE
DRAWN	J.P.KAUSHIK	12-07-2019
CHECKED		
APPROVED	J.N.RAI	18-07-2019
SCALE		1:1
AREA mm ²		398.948
PERIMETER mm.		268.925
WEIGHT kg/m		1.077
DRAWING No.	SECTION No.	
P-19838	-	
36122	36122	

1. ALL DIMENSIONS ARE IN mm.
2. ROUND OFF ALL SHARP CORNERS WITH 0.40 mm.
3. TOLERANCES WILL BE AS PER IS:6477-1983 , UNLESS OTHERWISE SPECIFIED

PARTY'S NAME	GENERAL CATEGORY, KOLKATA MARKET
PARTY'S DRAWING No.	AS PER SAMPLE
ALLOY & TEMPER	6063 T6
DESCRIPTION	CURTAIN WALL SECTION