

P-19839

36123

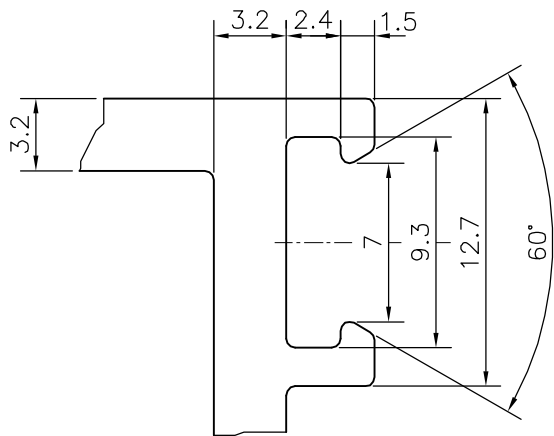

DETAIL OF "B"  
SCALE 3:1

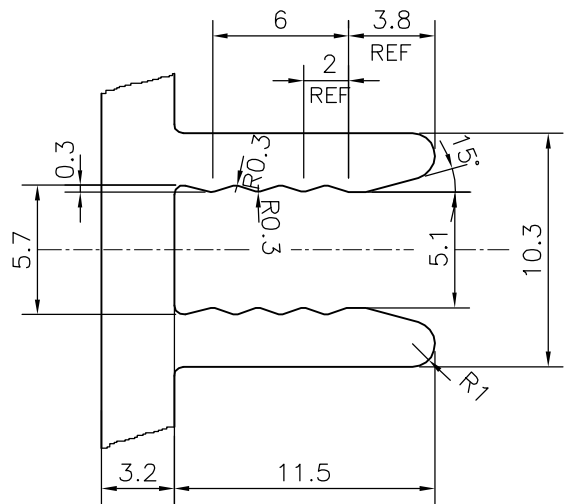

DETAIL OF "A"  
SCALE 3:1

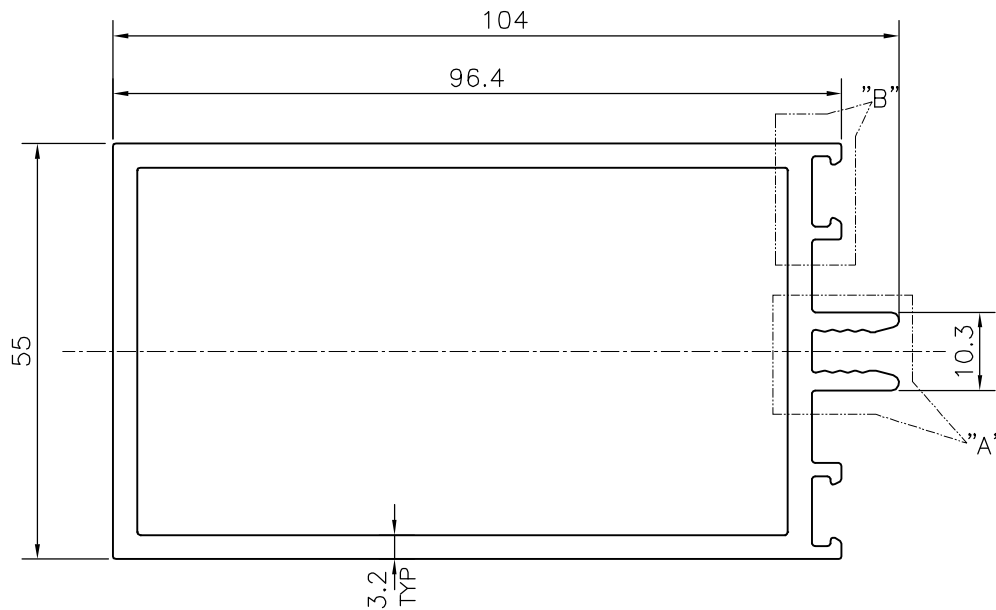

SYMBOL OF QUALITY  
AN ISO 9001 COMPANY

**JINDAL ALUMINIUM LTD.**  
BANGALORE-560073 (INDIA)

	NAME	DATE
DRAWN	J.P.KAUSHIK	12-07-2019
CHECKED		
APPROVED	J.N.RAI	18-07-2019
SCALE		1:1
AREA mm <sup>2</sup>		989.682
PERIMETER mm.		373.886
WEIGHT kg/m		2.672
DRAWING No.	SECTION No.	
P-19839	-	
36123	36123	

1. ALL DIMENSIONS ARE IN mm.
2. ROUND OFF ALL SHARP CORNERS WITH 0.40 mm.
3. TOLERANCES WILL BE AS PER IS:6477-1983 , UNLESS OTHERWISE SPECIFIED

PARTY'S NAME	GENERAL CATEGORY, KOLKATA MARKET
PARTY'S DRAWING No.	AS PER SAMPLE
ALLOY & TEMPER	6063 T6
DESCRIPTION	CURTAIN WALL SECTION