

P-17258

S5433

36139

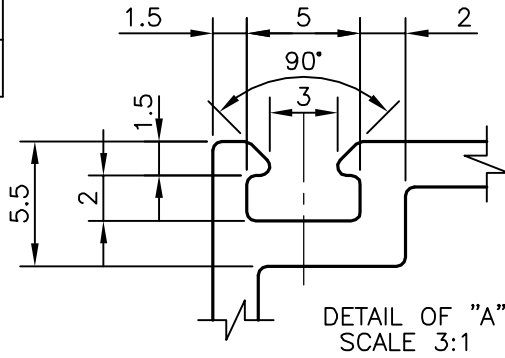

DETAIL OF "B"
SCALE 3:1

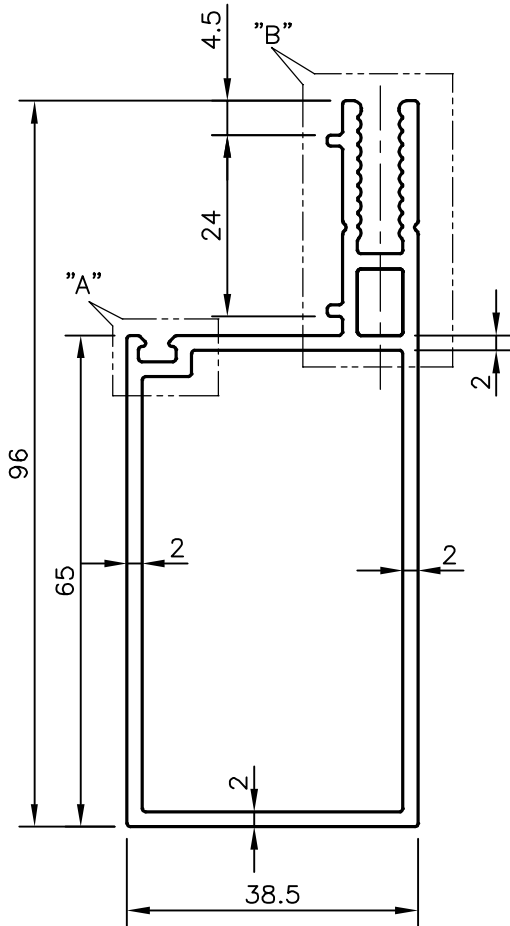
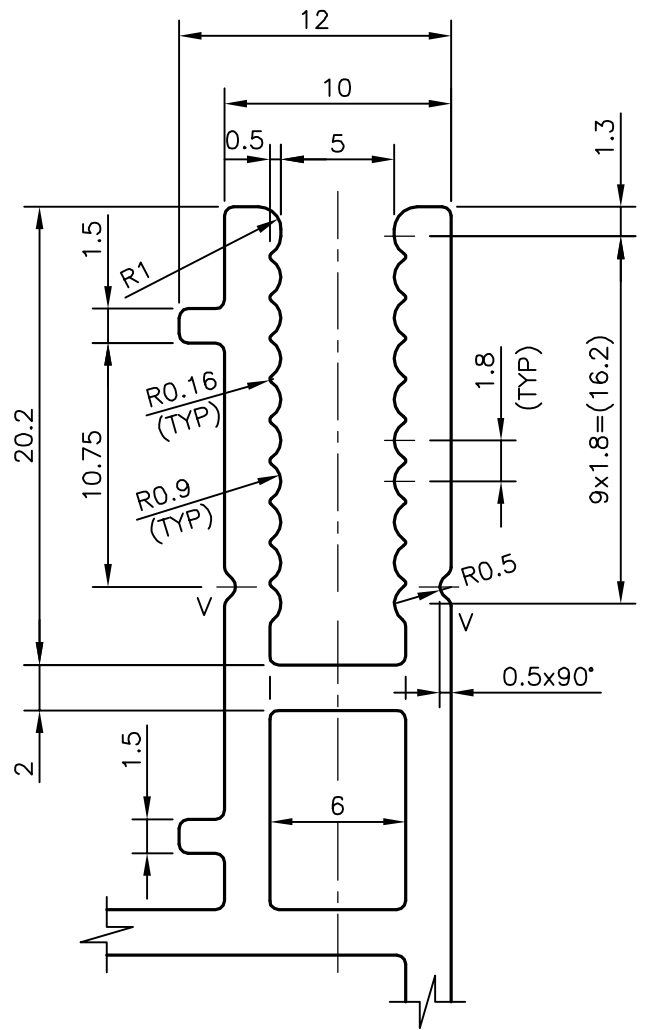

V = 'V'-GROOVE 0.5x90° (2 PLACES)

TOLERANCES ON OVERALL DIMENSIONS OF HOLLOW SECTIONS

UPTO 20.0mm - ±0.30	UPTO 80.0mm - ±0.70	UPTO 180.0mm - ±1.27	1. STRAIGHTNESS=1.7mm/M 2. TWIST=1.7mm/M 3. ANGULARITY= ±2° 4. FLATNESS =0.006xWIDTH
UPTO 30.0mm - ±0.38	UPTO 100.0mm - ±0.80	UPTO 200.0mm - ±1.40	
UPTO 40.0mm - ±0.45	UPTO 120.0mm - ±0.90	UPTO 225.0mm - ±1.52	
UPTO 50.0mm - ±0.52	UPTO 140.0mm - ±1.00		
UPTO 60.0mm - ±0.60	UPTO 160.0mm - ±1.14		

	JINDAL ALUMINIUM LTD. BANGALORE-560073 (INDIA)	NAME	DATE
		DRAWN	J.P.KAUSHIK 13-06-2017
		CHECKED	
		APPROVED	B.NATARAJA 22-06-2017
		SCALE	1:1
		AREA mm ²	558.624
		PERIMETER mm.	330.888
		WEIGHT kg/m	1.508
		DRAWING No.	SECTION No.
		P-17258	-
		S5433	S5433
		36139	36139
PARTY'S NAME	FABICON FACADE SYSTEMS PVT. LTD., BANGALORE		
PARTY'S DRAWING No.	AS PER DRAWING-7723		
ALLOY & TEMPER	6063 T6		
DESCRIPTION	CURTAIN WALL SECTION		

1. ALL DIMENSIONS ARE IN mm.
2. ROUND OFF ALL SHARP CORNERS WITH 0.40 mm.
3. TOLERANCES WILL BE AS PER IS:6477-1983 UNLESS OTHERWISE SPECIFIED