

P-17720

X2286

36161

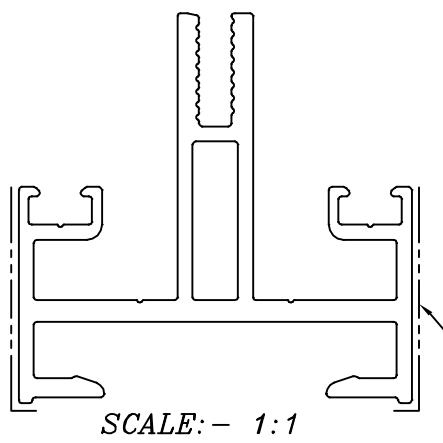
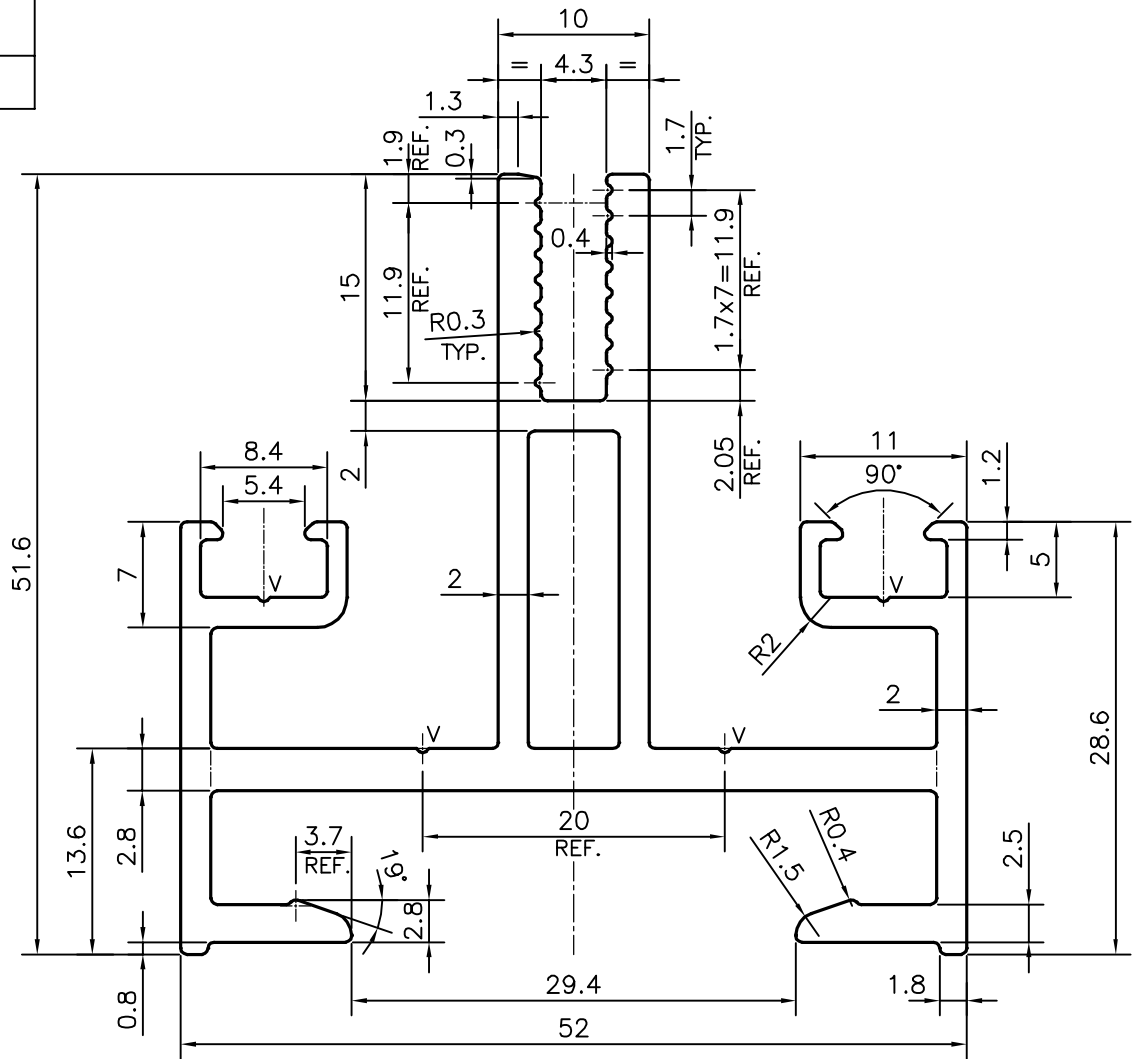

EXPOSED SURFACE

V = VEE GROOVE 0.3x90° (4 PLACES)



SYMBOL OF QUALITY
AN ISO 9001 COMPANY

JINDAL ALUMINIUM LTD.
BANGALORE-560073 (INDIA)

	NAME	DATE
DRAWN	PARVESH	20-12-2017
CHECKED		
APPROVED	B.NATARAJA	03-01-2018
SCALE		2:1
AREA mm ²		524.363
PERIMETER mm.		418.143
WEIGHT kg/m		1.416
DRAWING No.	SECTION No.	
P-17720	-	
X2286	X2286	
36161	36161	

1. ALL DIMENSIONS ARE IN mm.
2. ROUND OFF ALL SHARP CORNERS WITH 0.4 mm.
3. TOLERANCES WILL BE AS PER IS:6477-1983 , UNLESS OTHERWISE SPECIFIED

PARTY'S NAME	GSC GLASS LTD., NOIDA
PARTY'S DRAWING No.	M34832-REVA3
ALLOY & TEMPER	6063 T6
DESCRIPTION	CURTAIN WALL SECTION