

P-17734

S5631

36162

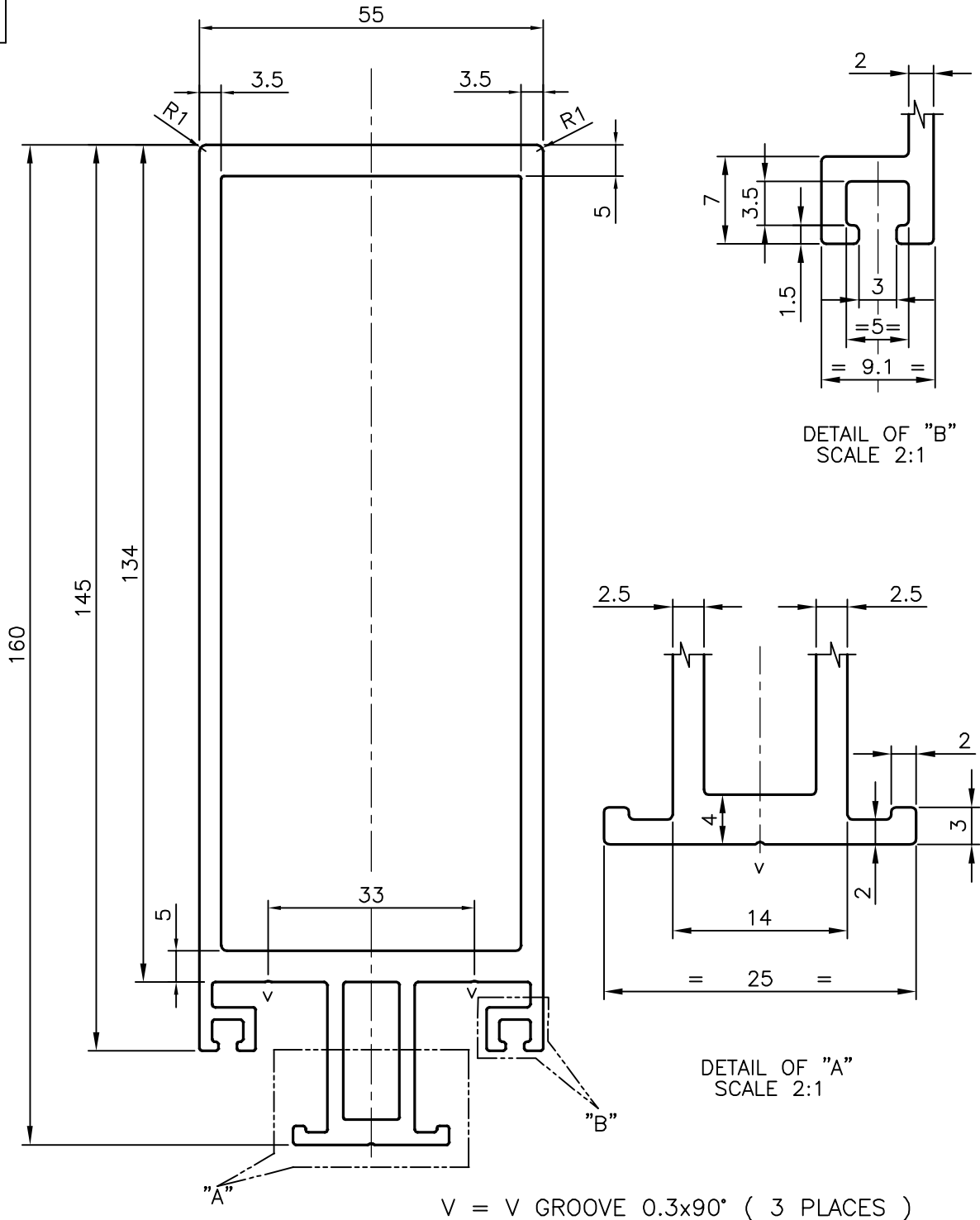

JINDAL ALUMINIUM LTD.
 BANGALORE-560073 (INDIA)

	NAME	DATE
DRAWN	J.P.KAUSHIK	23-12-2017
CHECKED		
APPROVED	B.NATARAJA	01-01-2018
SCALE		1:1
AREA mm ²		1707.769
PERIMETER mm.		548.844
WEIGHT kg/m		4.611
DRAWING No.	SECTION No.	
P-17734	-	
S5631	S5631	
36162	36162	

1. ALL DIMENSIONS ARE IN mm. 2. ROUND OFF ALL SHARP CORNERS WITH 0.40 mm. 3. TOLERANCES WILL BE AS PER IS:6477-1983 UNLESS OTHERWISE SPECIFIED	
PARTY'S NAME	TRUEWALL SPECIALITIES PVT. LTD., MUMBAI
PARTY'S DRAWING No.	AS PER DRAWING
ALLOY & TEMPER	6063 T6
DESCRIPTION	CURTAIN WALL-MULLION SECTION