

P-21530-1

36216

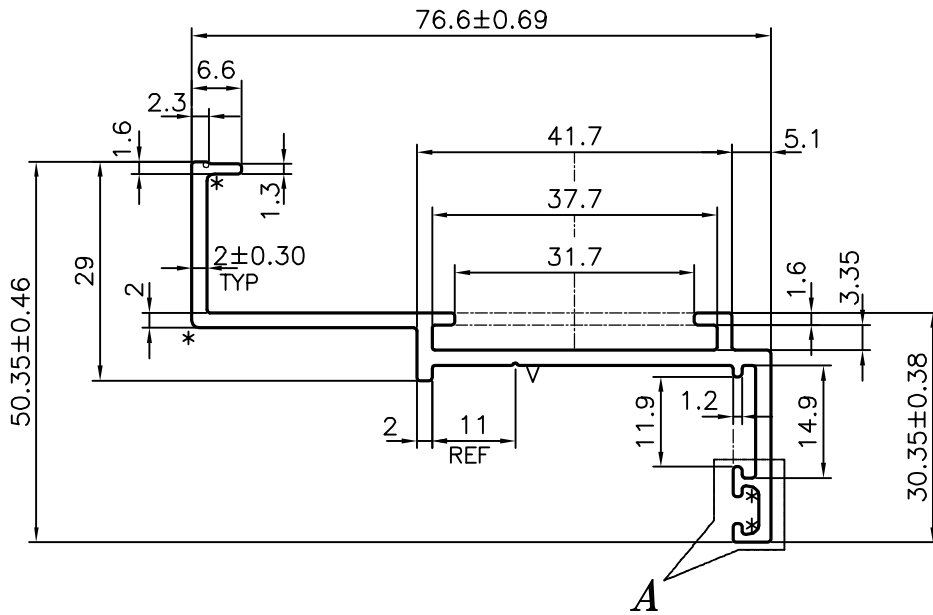
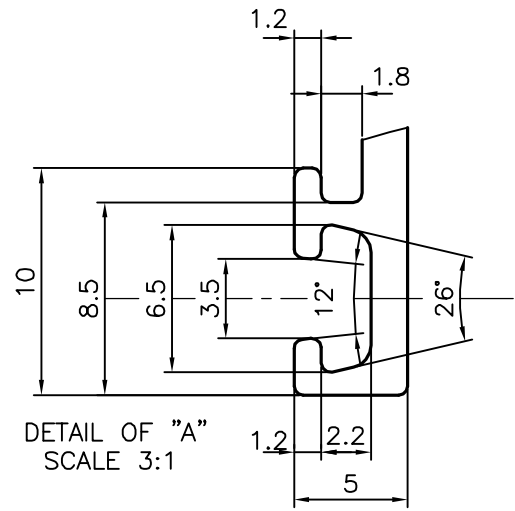

AVERAGE WEIGHT:-0.713 kg/m TO 0.871 kg/m

\* = 1.0 RADIUS (4 PLACES)

V = V GROOVE 0.30x90°(1 PLACE)



SYMBOL OF QUALITY  
AN ISO 9001 COMPANY

**JINDAL ALUMINIUM LTD.**  
BANGALORE-560073 (INDIA)

	NAME	DATE
DRAWN	J.P.KAUSHIK	19-09-2020
CHECKED		
APPROVED	B.NATARAJA	24-09-2020

1. ALL DIMENSIONS ARE IN mm.
2. ROUND OFF ALL SHARP CORNERS WITH 0.40 mm.
3. TOLERANCES WILL BE AS PER IS:3965-1981 UNLESS OTHERWISE SPECIFIED

SCALE	1:1
AREA mm <sup>2</sup>	290.679
PERIMETER mm.	305.549
WEIGHT kg/m	0.785

PARTY'S NAME	HATIM GLAZING & CLADDING PVT. LTD., MUMBAI
PARTY'S DRAWING No.	AS PER DRAWING
ALLOY & TEMPER	6063 T6
DESCRIPTION	CURTAIN WALL SECTION

DRAWING No.	SECTION No.
P-21530-1	-
36216	36216