

P-21696

36238

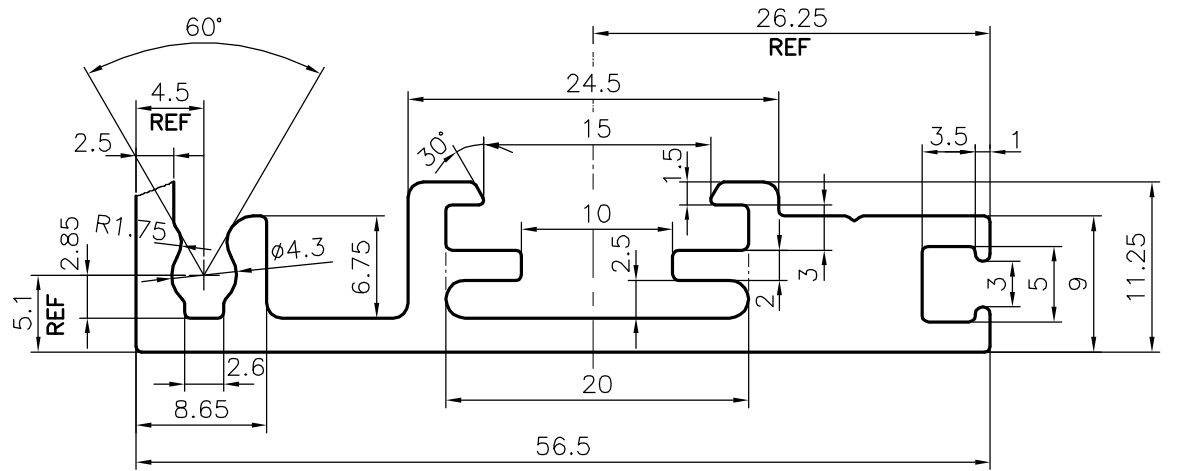

DETAIL OF "A"
SCALE 2:1

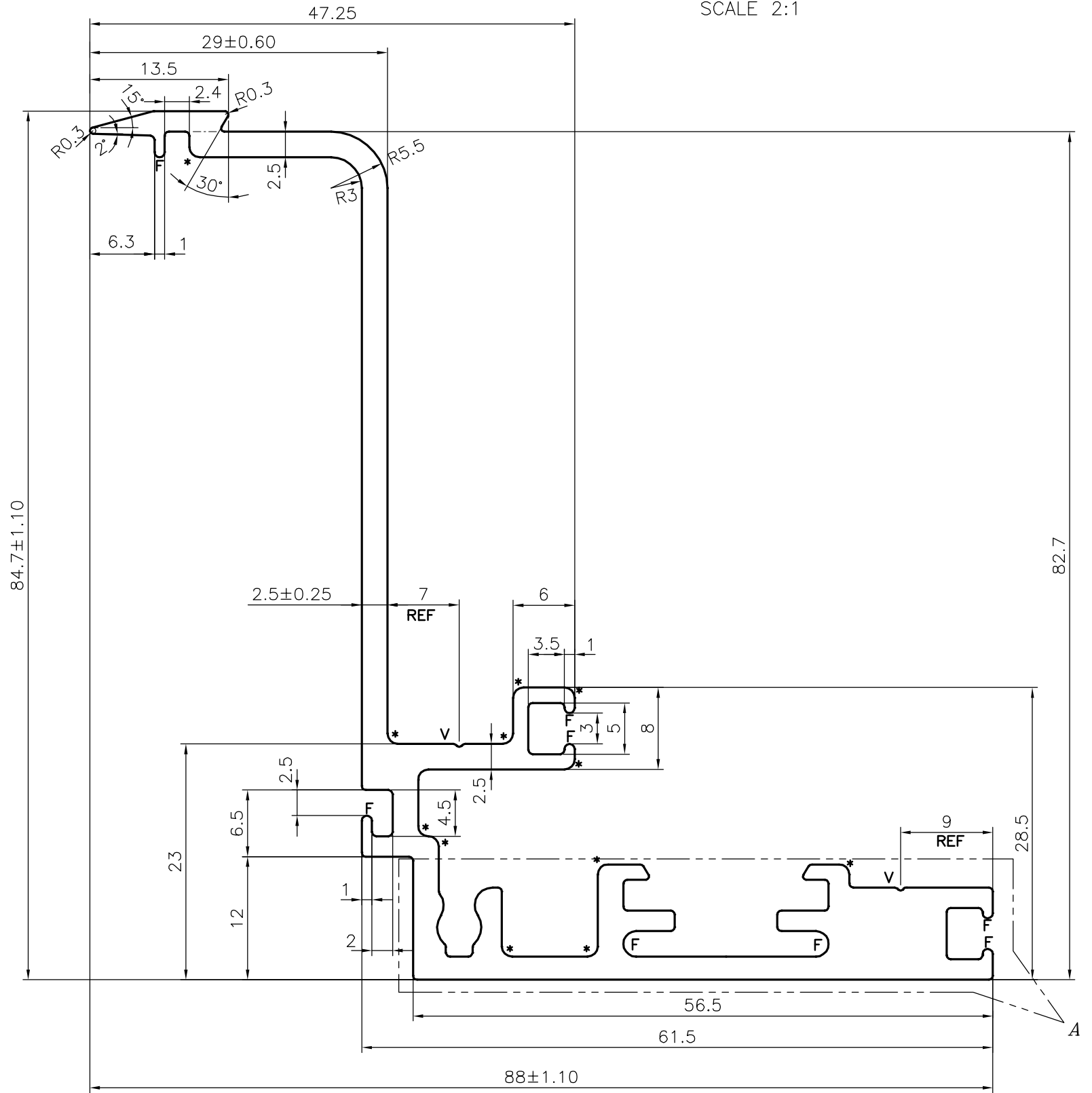

* = 1.0 RADIUS (12 PLACES)
F = FULL RADIUS (8 PLACES)
V = V GROOVE 0.3x90° (2 PLACES)

APPROXIMATE WEIGHT RANGE - 1.522 kg/m TO 1.861 kg/m

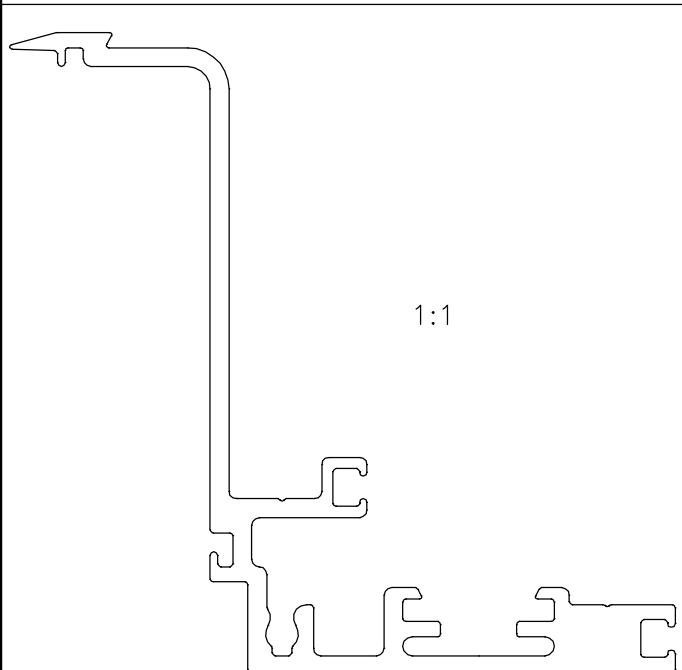

1:1

 SYMBOL OF QUALITY AN ISO 9001 COMPANY	JINDAL ALUMINIUM LTD. BANGALORE-560073 (INDIA)	NAME	DATE
		DRAWN	J.P.KAUSHIK 19-10-2020
		CHECKED	
		APPROVED	B.NATARAJA 26/11/2020
		SCALE	2:1
		AREA mm ²	626.788
		PERIMETER mm.	485.03
		WEIGHT kg/m	1.692
PARTY'S NAME	FACADE CLAD TECH PVT. LTD., BANGALORE	DRAWING No.	SECTION No.
PARTY'S DRAWING No.	AS PER DRAWING	P-21696	-
ALLOY & TEMPER	6063 T6	36238	36238
DESCRIPTION	MISC. SECTION		