

IAL-D-7294

36415

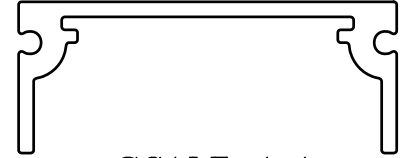

SCALE 1:1

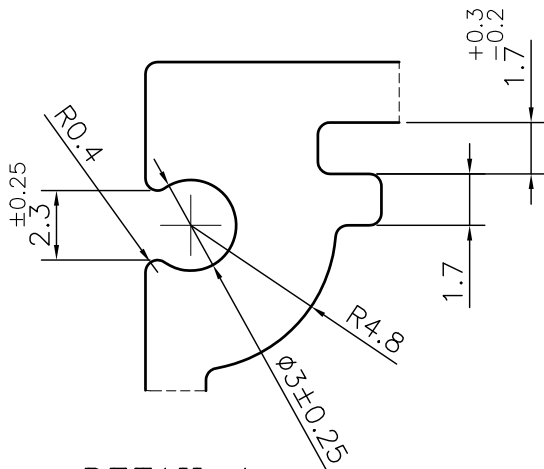
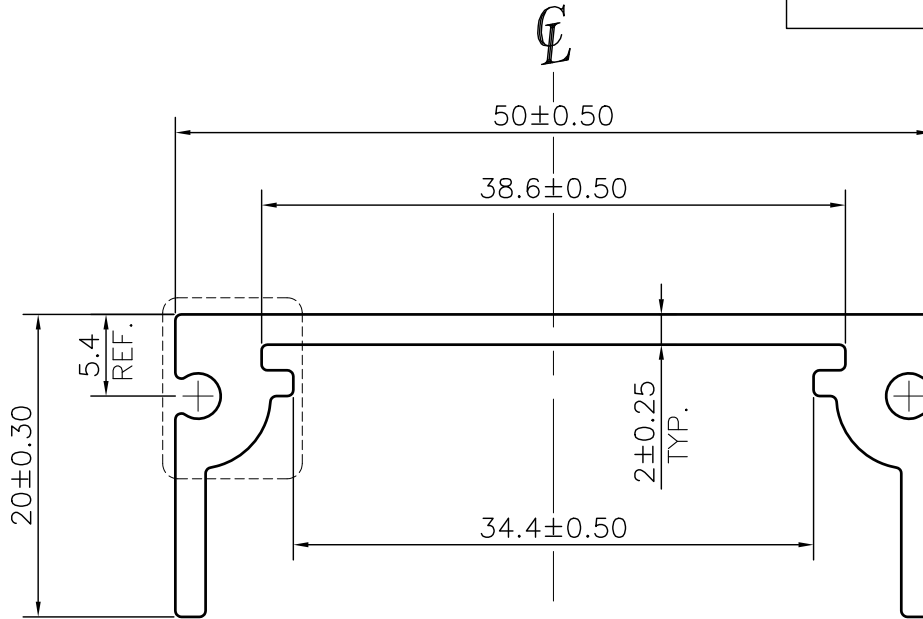

DETAIL A
SCALE 4:1

1. STRAIGHTNESS= 1.7mm/M
2. TWIST= 1.7mm/M
3. ANGULARITY= ±2°
4. FLATNESS= 0.007xWIDTH



SYMBOL OF QUALITY
AN ISO 9001 COMPANY

JINDAL ALUMINIUM LTD.
BHIWAID-301019 (INDIA)

	NAME	DATE
DRAWN	ASHUTOSH	24-08-2023
CHECKED		
APPROVED		
SCALE		2:1
AREA mm ²		220.561
PERIMETER mm.		187.79
WEIGHT kg/m		0.596
DRAWING No.	SECTION No.	
IAL-D-7294	-	
36415	36415	

1. ALL DIMENSIONS ARE IN mm.
2. ROUND OFF ALL SHARP CORNERS WITH 0.40 mm.
3. TOLERANCES WILL BE AS PER BS:EN-755-9 , UNLESS OTHERWISE SPECIFIED

PARTY'S NAME	DURLUM	
PARTY'S DRAWING No.	AS PER DRAWING	
ALLOY & TEMPER	6063 T6	PRODUCT CODE:-055
		HSN CODE:- 76042990
DESCRIPTION	CURTAIN WALL SECTION	