

IAL-D-3157

36450

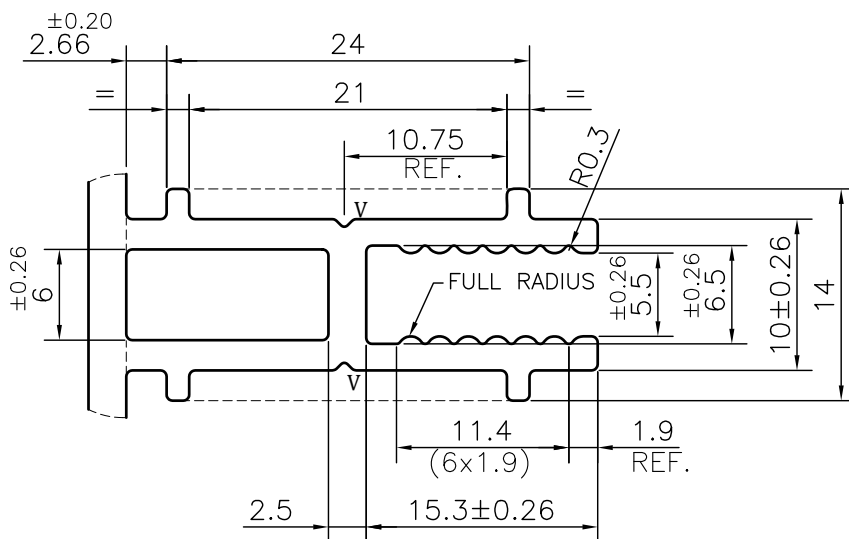

DETAIL A
SCALE 2:1

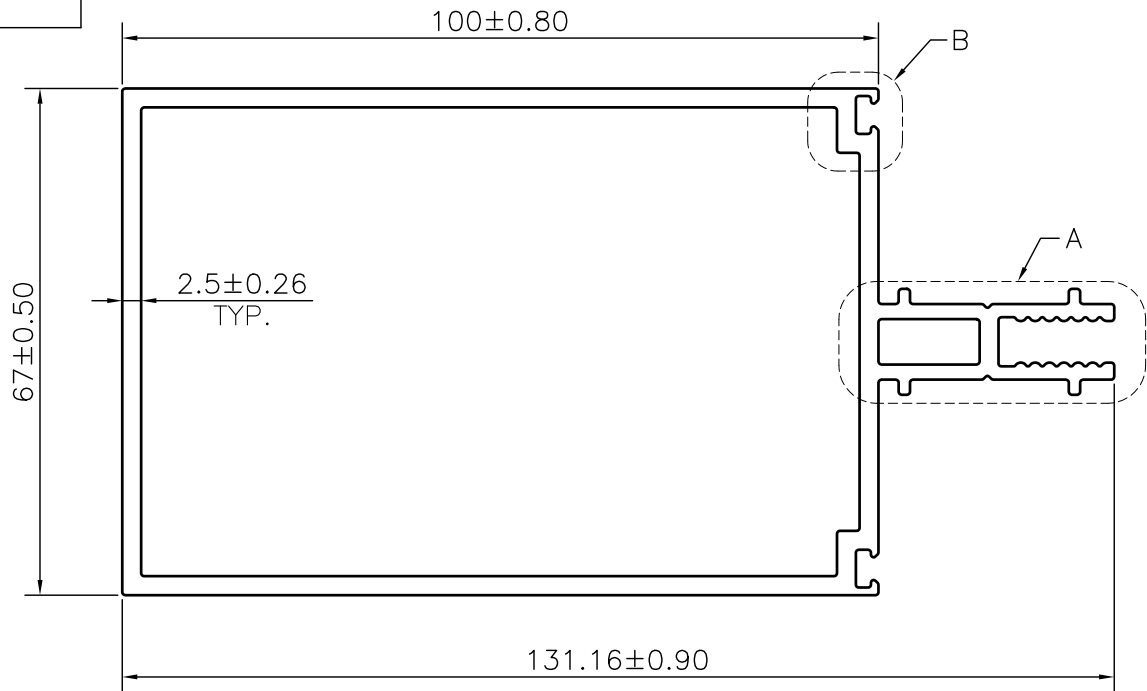
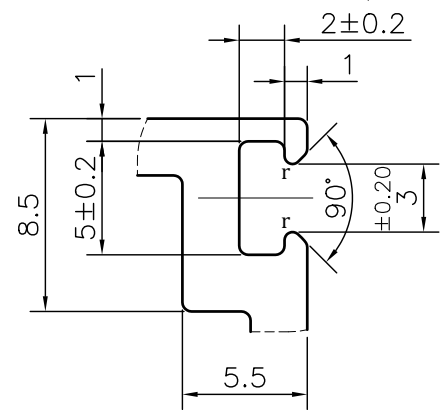

DETAIL B
SCALE 3:1

NOTE:-**r = 0.35 RADIUS (4 PLACES)****V = 0.50x90° V-GROOVE (2 PLACES)**

1. STRAIGHTNESS= 1.7mm/M
2. TWIST= 1.7mm/M
3. ANGULARITY= ±2°
4. FLATNESS= 0.007xWIDTH



SYMBOL OF QUALITY
AN ISO 9001 COMPANY

JINDAL ALUMINIUM LTD.
BHIWADI-301019 (INDIA)

	NAME	DATE
DRAWN	ASHUTOSH	12-10-2023
CHECKED		
APPROVED		
SCALE		1:1
AREA mm ²		971.33
PERIMETER mm.		460.869
WEIGHT kg/m		2.623
DRAWING No.	SECTION No.	
IAL-D-3157	-	
36450	36450	

1. ALL DIMENSIONS ARE IN mm.
2. ROUND OFF ALL SHARP CORNERS WITH 0.40 mm.
3. TOLERANCES WILL BE AS PER BS:EN-755-9 , UNLESS OTHERWISE SPECIFIED

PARTY'S NAME	AAP DIVISION	
PARTY'S DRAWING No.	AS PER DRAWING	
ALLOY & TEMPER	6063 T6	PRODUCT CODE:-055
		HSN CODE:- 76042100
DESCRIPTION	CURTAIN WALL SECTION	