

P-11755
X1610
38015

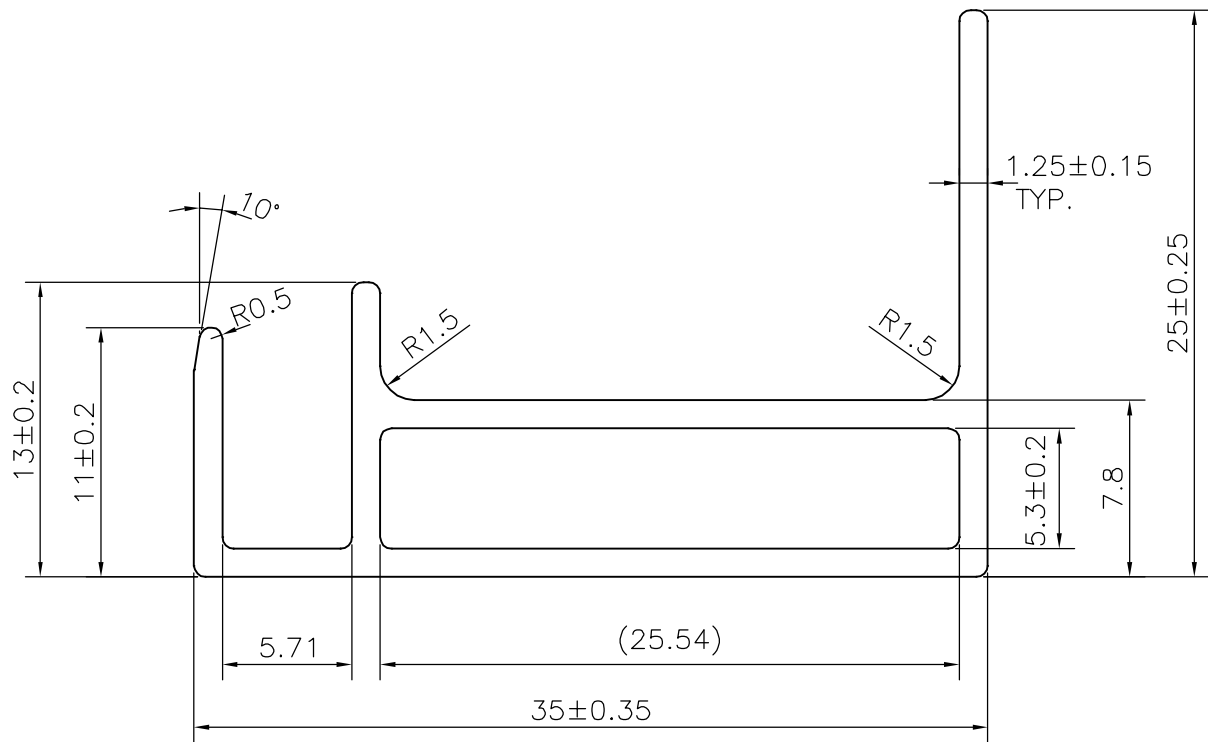
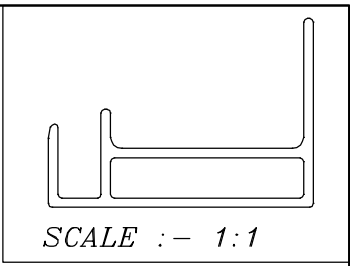

**JINDAL ALUMINIUM LTD.**  
 BANGALORE-560073 (INDIA)

	NAME	DATE
DRAWN	PARVESH	10-05-2012
CHECKED		
APPROVED	S.S.CARG	17-08-2012

1. ALL DIMENSIONS ARE IN mm.
2. ROUND OFF ALL SHARP CORNERS WITH 0.50 mm.
3. TOLERANCES WILL BE AS PER IS:6477-1983 , UNLESS OTHERWISE SPECIFIED

SCALE	3:1
AREA mm <sup>2</sup>	132.805
PERIMETER mm.	146.238
WEIGHT kg/m	0.359

PARTY'S NAME	EMMVEE PHOTOVOLTAIC POWER PVT. LTD., BANGALORE
--------------	---

DRAWING No.	SECTION No.
-------------	-------------

PARTY'S DRAWING No.	MV-PV-E-004B
---------------------	--------------

P-11755	-
---------	---

ALLOY & TEMPER	6063 T5
----------------	---------

X1610	X1610
38015	38015

DESCRIPTION	SOLAR SECTION
-------------	---------------

--	--