

P-13505

S4080

38504



SCALE: - 1:1

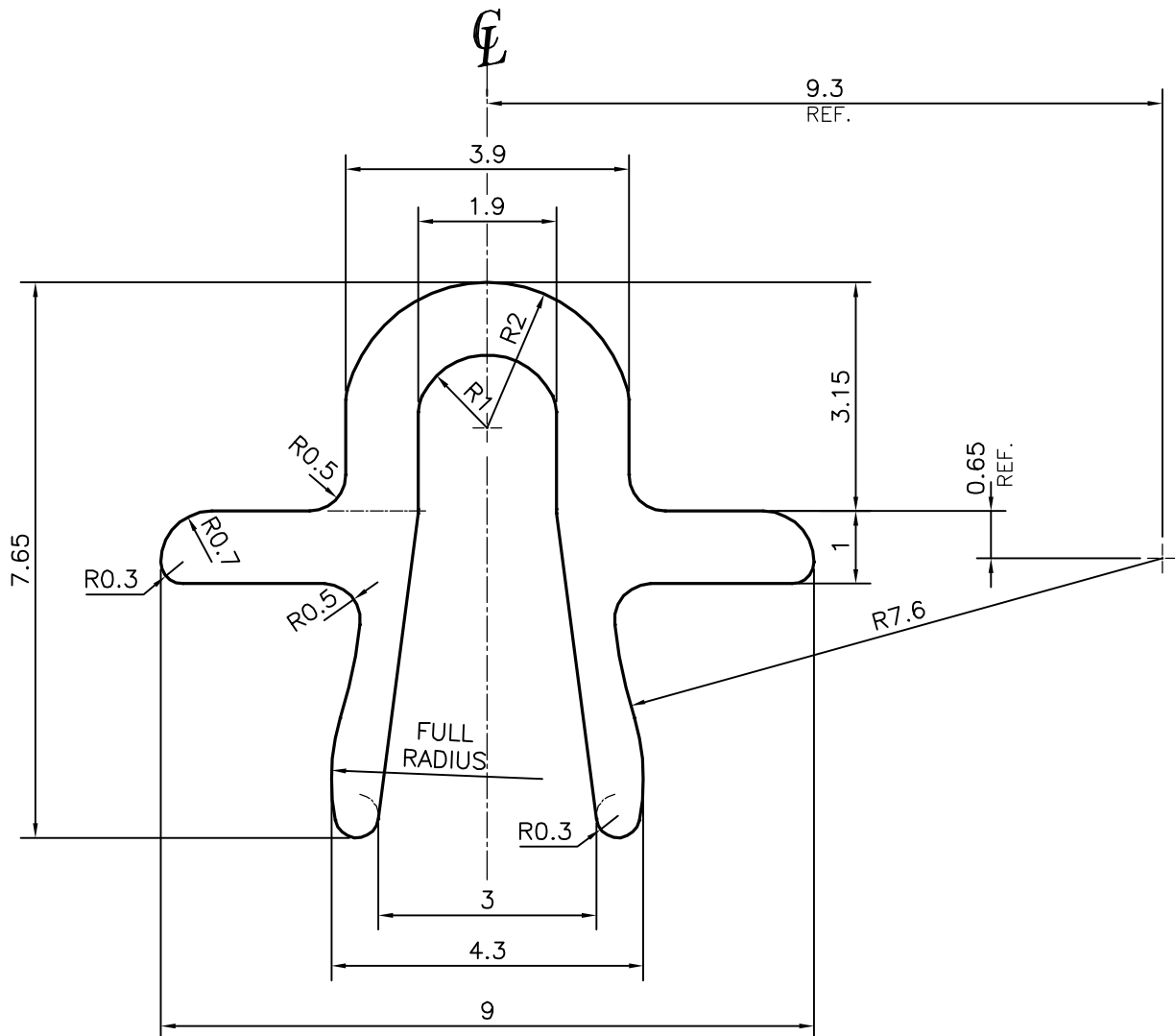

TOLERANCES ON OVERALL WIDTHS & WIDTHS ACROSS FLATS OF BARS, & REGULAR SECTIONS

UPTO 6.40mm - ± 0.20	UPTO 32.0mm - ± 0.38	UPTO 120.0mm - ± 0.85	1. STRAIGHTNESS=1.7mm/M 2. TWIST=1.7mm/M 3. ANGULARITY= $\pm 2^\circ$ 4. FLATNESS =0.007xWIDTH
UPTO 10.0mm - ± 0.23	UPTO 50.0mm - ± 0.46	UPTO 160.0mm - ± 1.02	
UPTO 12.0mm - ± 0.25	UPTO 60.0mm - ± 0.53	UPTO 200.0mm - ± 1.14	
UPTO 16.0mm - ± 0.28	UPTO 80.0mm - ± 0.69	UPTO 250.0mm - ± 1.40	
UPTO 25.0mm - ± 0.30	UPTO 100.0mm - ± 0.75	UPTO 300.0mm - ± 1.65	



SYMBOL OF QUALITY
AN ISO 9001 COMPANY

JINDAL ALUMINIUM LTD.
BANGALORE-560073 (INDIA)

	NAME	DATE
DRAWN	PARVESH	07-04-2014
CHECKED		
APPROVED	S.S.GARG	16-04-2014

1. ALL DIMENSIONS ARE IN mm.
2. ROUND OFF ALL SHARP CORNERS WITH 0.50 mm.
3. TOLERANCES WILL BE AS PER IS:3965-1981, UNLESS OTHERWISE SPECIFIED

SCALE	10:1
AREA mm ²	18.482
PERIMETER mm.	41.729
WEIGHT kg/m	0.05

PARTY'S NAME	RACHANA FENESTRAA PVT. LTD., BANGALORE	DRAWING No.	P-13505	SECTION No.	-
PARTY'S DRAWING No.	AS PER AUTOCAD DRAWING-104.748		S4080		S4080
ALLOY & TEMPER	HE9 WP		38504		38504
DESCRIPTION	ARCHITECTURAL SECTION				