

P-13502-1

S4091

38505

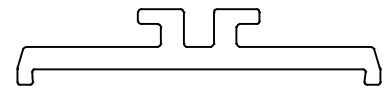

SCALE: - 1:1

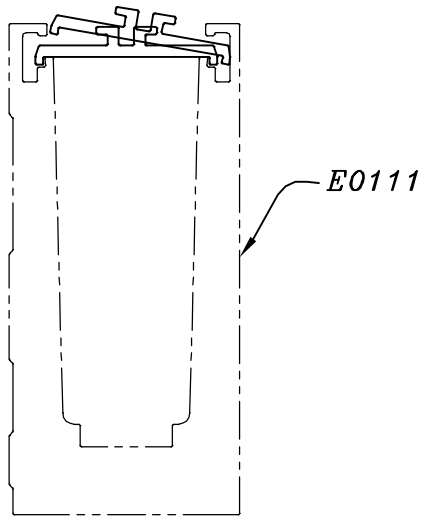
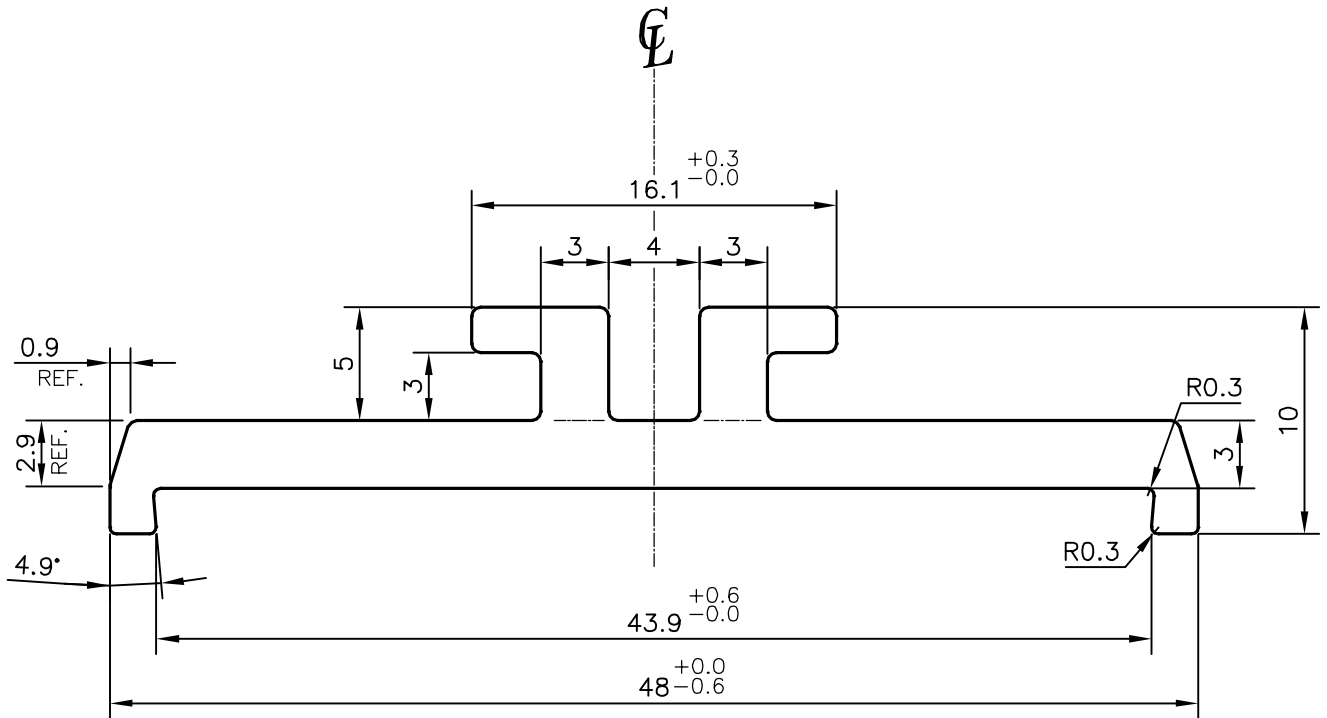

TOLERANCE CHART CD = CIRCUMSCRIBING CIRCLE

DIMENSION	CD<100	100<CD<200	200<CD<300	300<CD<500
UPTO 10mm	±0.25	±0.30	±0.35	±0.40
10.0 - 25.0	±0.30	±0.40	±0.50	±0.60
25.0 - 50.0	±0.50	±0.60	±0.80	±0.90
50.0 - 100	±0.70	±0.90	±1.10	±1.30
100 - 150	-	±1.10	±1.30	±1.50
150 - 200	-	±1.3	±1.50	±1.80
200 - 300	-	-	±1.70	±2.10
300 - 450	-	-	-	±2.80



SYMBOL OF QUALITY
AN ISO 9001 COMPANY

JINDAL ALUMINIUM LTD.
BANGALORE-560073 (INDIA)

	NAME	DATE
DRAWN	PARVESH	15-04-2014
CHECKED		
APPROVED	S.S.GARG	26-04-2014

1. ALL DIMENSIONS ARE IN mm.
2. ROUND OFF ALL SHARP CORNERS WITH 0.40 mm.
3. TOLERANCES WILL BE AS PER BS:EN-755-9, UNLESS OTHERWISE SPECIFIED

SCALE	3:1
AREA mm ²	191.483
PERIMETER mm.	137.921
WEIGHT kg/m	0.517

PARTY'S NAME: GSC GLASS PVT LTD., NOIDA

PARTY'S DRAWING No.: M31785

ALLOY & TEMPER: HE9 WP

DESCRIPTION: ARCHITECTURAL SECTION

DRAWING No.	SECTION No.
P-13502-1	-
S4091	S4091
38505	38505