

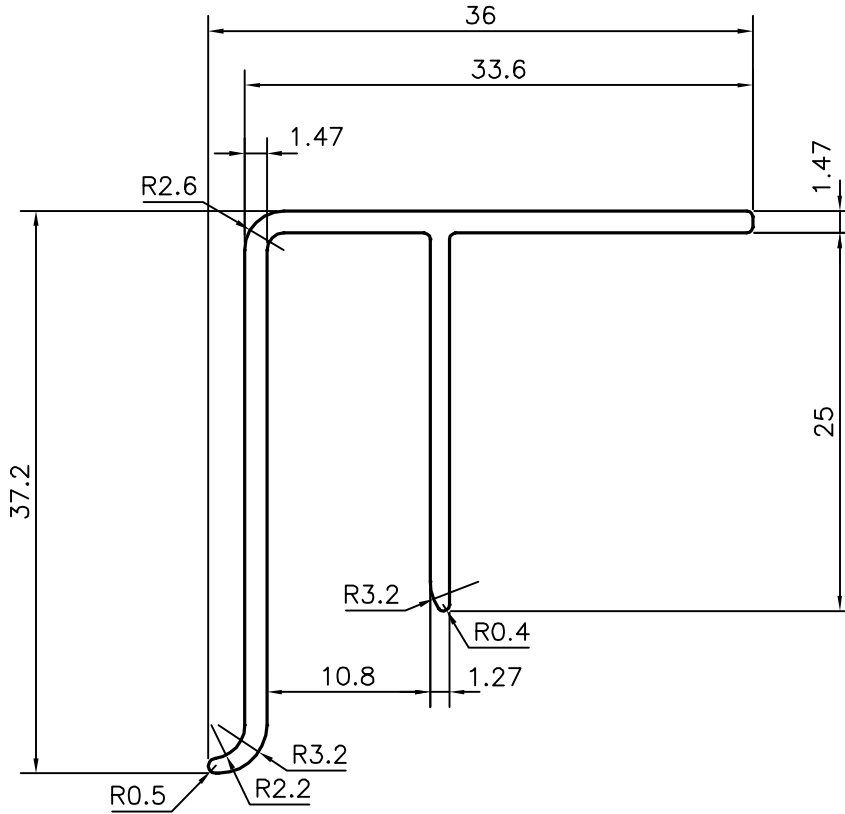

P-13542
S4099
38522

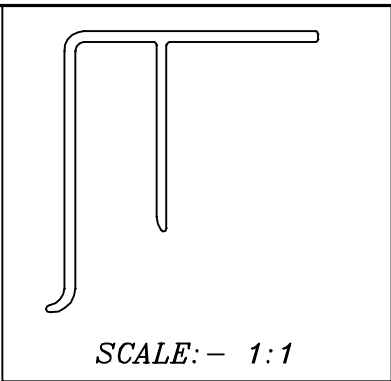

ISSUE (2) :- PROFILE & DIMENSIONS CHANGED AS PER CUSTOMER REQUIREMENT.

0.0mm - ±0.28	UPTO 32.0mm - ±0.38	UPTO 120.0mm - ±0.85
UPTO 25.0mm - ±0.30	UPTO 50.0mm - ±0.46	UPTO 160.0mm - ±1.02
	UPTO 60.0mm - ±0.53	UPTO 200.0mm - ±1.14
	UPTO 80.0mm - ±0.69	UPTO 250.0mm - ±1.40
	UPTO 100.0mm - ±0.75	UPTO 300.0mm - ±1.65

 SYMBOL OF QUALITY AN ISO 9001 COMPANY	JINDAL ALUMINIUM LTD. BANGALORE-560073 (INDIA)	NAME	DATE
		DRAWN	06-09-2014
		CHECKED	
		APPROVED	S.S.GARG 12-09-2014
1. ALL DIMENSIONS ARE IN mm. 2. ROUND OFF ALL SHARP CORNERS WITH 0.40 mm. 3. TOLERANCES WILL BE AS PER IS:3965-1981, UNLESS OTHERWISE SPECIFIED		SCALE	2:1
		AREA mm ²	133.135
		PERIMETER mm.	190.661
		WEIGHT kg/m	0.359
PARTY'S NAME	SAVEER BIOTECH LTD., NOIDA	DRAWING No.	SECTION No.
PARTY'S DRAWING No.	AS PER AUTOCAD DRAWING-SBBN-35	P-13542	-
ALLOY & TEMPER	6063 T6	38522	38522
DESCRIPTION	ARCHITECTURAL SECTION		